

Silicon Carbide Power MOSFET 650V N-Channel MOS
■ Applications

- Solar Inverters
- Switch Mode Power Supplies
- High Voltage DC/DC Converters
- Battery Chargers
- Motor Drives
- Pulsed Power applications

■ Features

- High Blocking Voltage with Low On-Resistance
- High Speed Switching with Low Capacitances
- Easy to Parallel and Simple to Drive
- Avalanche Ruggedness
- Halogen Free, RoHS Compliant

■ Benefits

- Higher System Efficiency
- Reduced Cooling Requirements
- Increased Power Density
- Increased System Switching Frequency

■ Product Summary

V_{DS}	650	V
I_D	30	A
$R_{DS(ON)}$, Typ@20V	60	m Ω
Q_g	65	nC

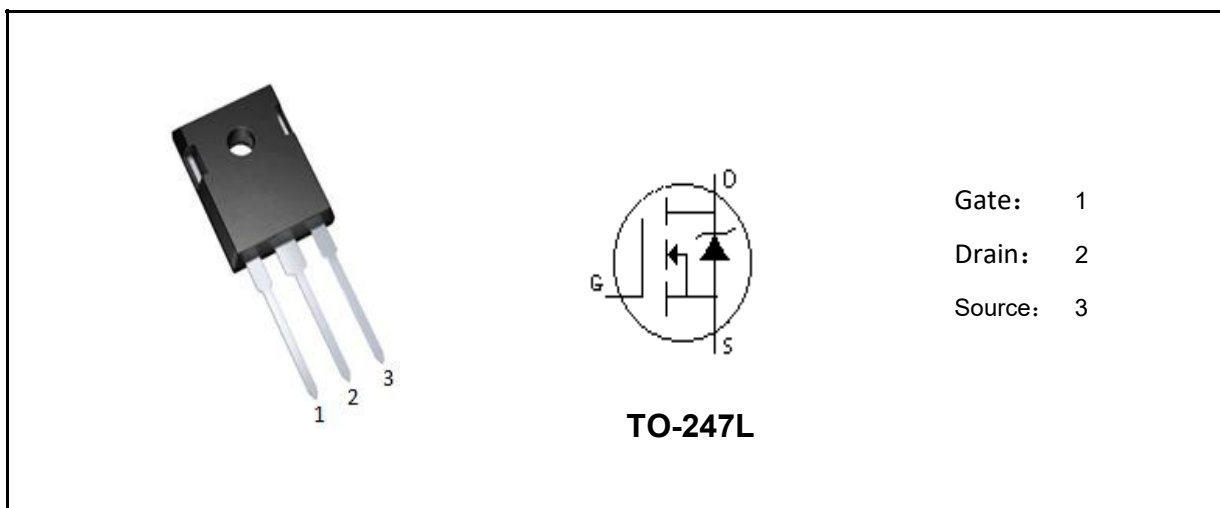

Marking	Package	Packaging	Min. package quantity
MSL3C060R065	TO-247L	Tube	450



■ Absolute Maximum Ratings (Tc=25°C unless otherwise noted)

Parameter	Symbol	Ratings	Unit
Drain-Source Voltage	V_{DS}	650	V
Gate-Source Voltage	V_{GS}	- 10/+25	V
Recommended operational values	V_{GSop}	- 5/+20	V
Continuous Drain Current Tc=25°C (Note 1)	I_D	30	A
Continuous Drain Current Tc=100°C (Note 1)		22	A
Drain Current-Pulsed (Note 1)	I_{DM}	65	A
Total Dissipation	P_D	171	W
Junction Temperature	T_j	150	°C
Storage Temperature	T_{stg}	- 55~150	°C

Note: Using continuously under heavy loads (e.g. the application of high temperature/current/voltage and the significant change in temperature, etc.) may cause this product to decrease in the reliability even if the operating conditions (i.e. operating temperature/current/voltage, etc.) are within the absolute maximum ratings.

■ Thermal Characteristics

Parameter	Symbol	Max	Unit
Maximum Junction-to-Case	$R_{\theta JC}$	0.73	°C/W
Maximum Junction-to-Ambient	$R_{\theta JA}$	40	°C/W

Note 1: Ensure that the channel temperature does not exceed 150°C.

Note: This transistor is sensitive to electrostatic discharge and should be handled with care.



■ Electrical Characteristics (Tc=25°C unless otherwise noted)

Parameter	Symbol	Test Condition	Min	Typ	Max	Unit
Static Parameters						
Drain-Source Breakdown Voltage	BV_{DSS}	$V_{GS}=0V, I_D=100\mu A$	650	-	-	V
Drain-Source Leakage Current	I_{DSS}	$V_{DS}=650V, V_{GS}=0V$	-	2	100	μA
Gate-Body Leakage Current	I_{GSS}	$V_{GS}=20V, V_{DS}=0V$	-	50	200	nA
Gate Threshold Voltage	$V_{GS(TH)}$	$V_{GS}=V_{DS}, I_{DS}=5mA$	2.0	2.4	4.0	V
Drain-Source On Resistance	$R_{DS(ON)}$	$V_{GS}=20V, I_D=20A$	-	60	80	m Ω
		Tj=150°C	-	95	-	
Transconductance	g_{fs}	$V_{GS}=20V, I_D=20A$	-	7	-	S
Dynamic Characteristics						
Input Capacitance	C_{iss}	$V_{DS}=1000V, V_{GS}=0V,$ $f=1.0MHz, V_{AC}=25$ mV	-	1700	-	pF
Output Capacitance	C_{oss}		-	172	-	pF
Reverse Transfer Capacitance	C_{rss}		-	77	-	pF
Gate Resistance	R_g	$V_{AC}=25mV,$ $f=1.0MHz$	-	1.0	-	Ω
Switching Paramters						
Turn-On Delay Time	$t_{d(on)}$	$V_{DD}=400V, V_{GS}=-0/20$ V $I_D = 10A, R_{G(ext)} = 5 \Omega$, $R_L=40\Omega$	-	15	-	ns
Turn-On Rise Time	t_r		-	45	-	ns
Turn-Off Delay Time	$t_{d(off)}$		-	13	-	ns
Turn-Off Fall Time	t_f		-	10	-	ns
Turn-On Switching Energy	E_{ON}	$V_{DS}=400V, V_{GS}=-$ $5/20V, I_D = 10A, R_{G(ext)}$ $= 5 \Omega, L=142\mu H$	-	140	-	μJ
Turn-Off Switching Energy	E_{OFF}		-	32	-	
Total Gate Charge	Q_g	$V_{DD}=400V, V_{GS}=-0/20$ V $I_D = 10A$	-	65	-	nC
Gate-Source Charge	Q_{gs}		-	18	-	nC
Gate-Drain Charge	Q_{gd}		-	19	-	nC
Source-Drain Characteristics						
Diode Forward Voltage	V_{sd}	$V_{GS} = -5V, I_{SD} = 10 A,$	-	3.5	-	V
Continuous Diode Forward Current	I_S	$T_C=25^\circ C$	-	-	30	A
Reverse Recovery Time	t_{rr}	$V_{GS}=-5V, I_{SD}=20A$ $V_R=400V$ $di/dt=1200A/\mu s$	-	16	-	ns
Reverse Recovery Charge	Q_{rr}		-	80	-	nC
Peak Reverse Recovery Current	I_{rm}		-	9.0	-	A





Characteristics Curves

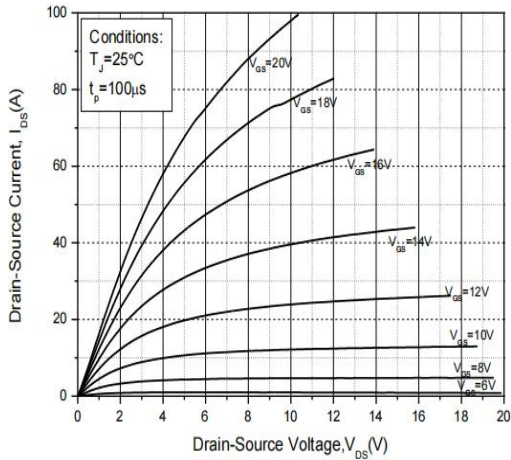

Output Characteristics $T_J = -25^\circ\text{C}$

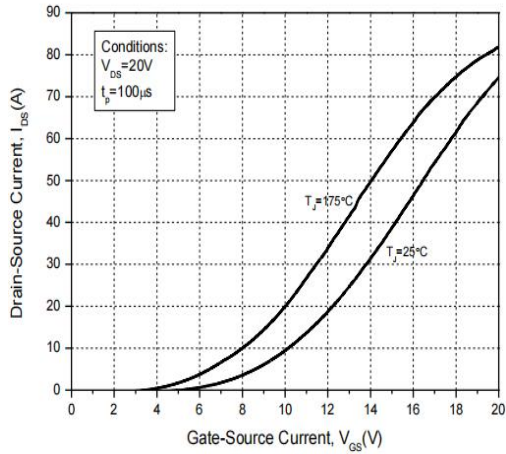

Transfer Characteristics

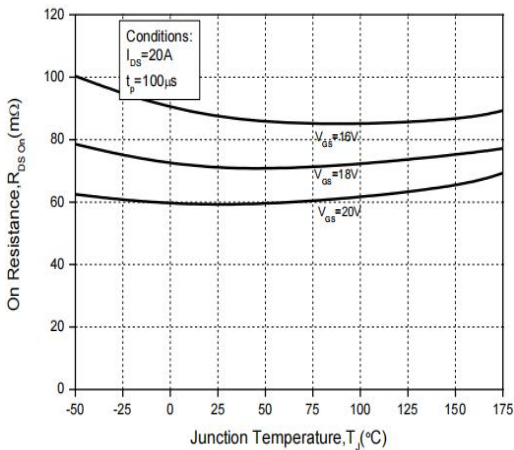

Normalized On-Resistance vs. Temperature

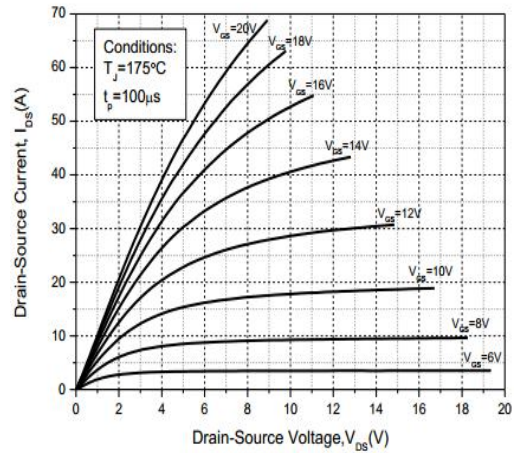

Output Characteristics $T_J = 25^\circ\text{C}$

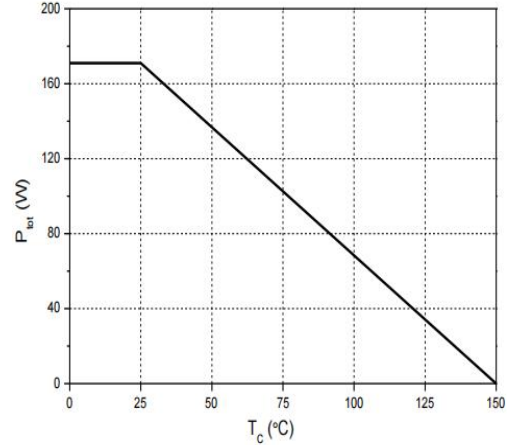

Power Dissipation Derating

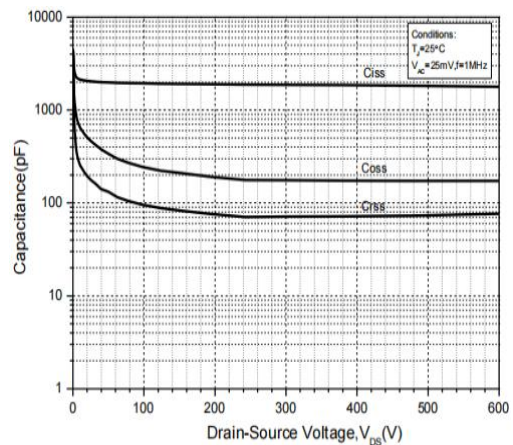

Capacitance



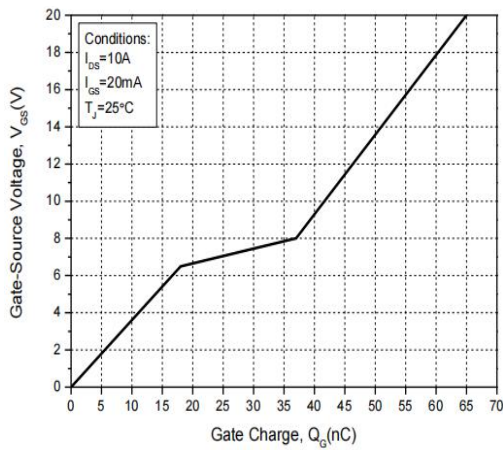

Gate Charge Waveform

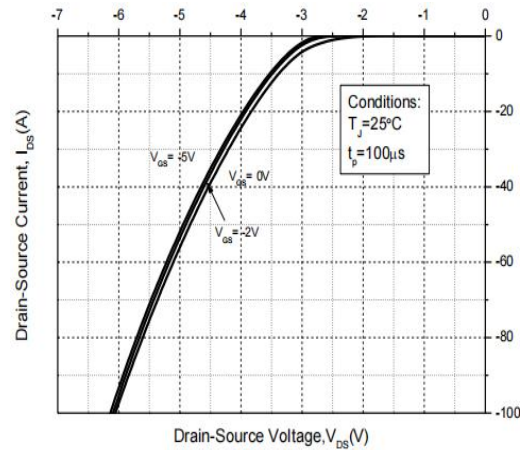

Source-Drain Diode Characteristics

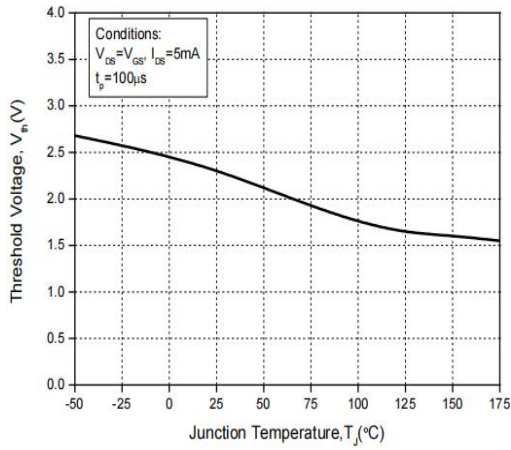

Threshold Voltage vs. Temperature

Note: The above characteristics curves are presented for reference only and not guaranteed by production test, unless otherwise noted.

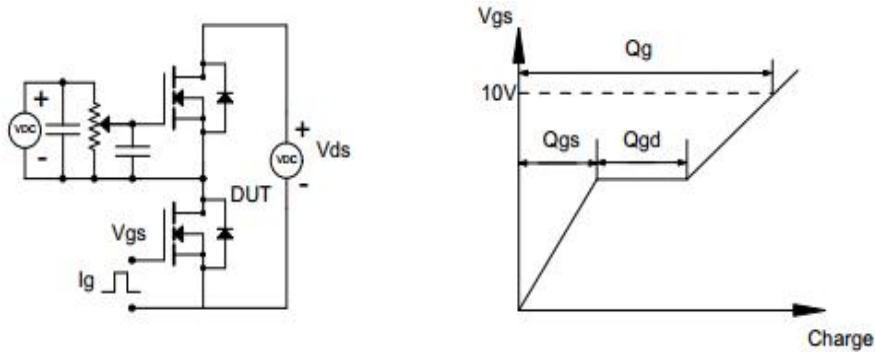
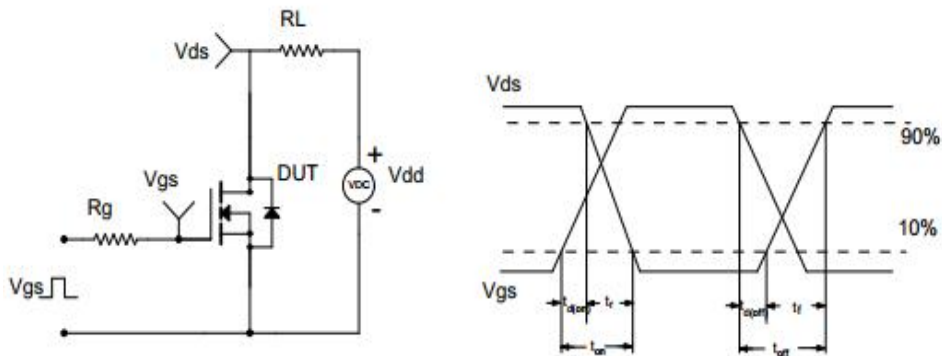
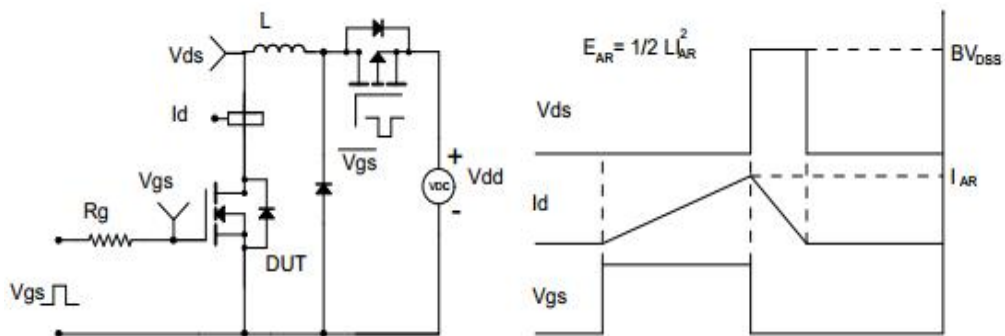

■ Test Circuit & Waveform
Gate Charge Test Circuit & Waveform

Resistive Switching Test Circuit & Waveform

Unclamped Inductive Switching (UIS) Test Circuit & Waveform



■ TO-247L Package Dimensions

Unit: mm

Symbol	Min	Nom	Max	Symbol	Min	Nom	Max
A	4.80		5.20	E1	13.00		13.60
A1	2.20	2.40	2.60	E2	5.00		5.50
A2	1.85		2.15	E3	1.90		2.60
b	1.07		1.33	e		5.44	
b2	1.90		2.16	L	19.30		19.90
b4	2.90		3.20	L1	3.75	3.95	4.15
c	0.52		0.68	ΦP	3.40		3.80
D	20.70		21.30	ΦP1	7.00		7.40
D1	16.15		16.95	S	6.04	6.15	6.30
E	15.50		16.10				

