

**MOSFETs Silicon 80V N-Channel MOS**
**■ Applications**

- Synchronous Rectification
- Industrial and Motor Drive
- DC/DC and AC/DC Converters
- Power Tools
- BMS

**■ Features**

- High-Speed Switching
- Low  $R_{DS(ON)}$
- Low Gate Charge
- RoHS and Halogen-Free Compliant
- 100% UIS and RG Tested

**■ Product Summary**

$V_{DS}$	80	V
$I_D$	460	A
$R_{DS(ON), Typ@10V}$	0.9	m $\Omega$
$Q_g$	323	nC

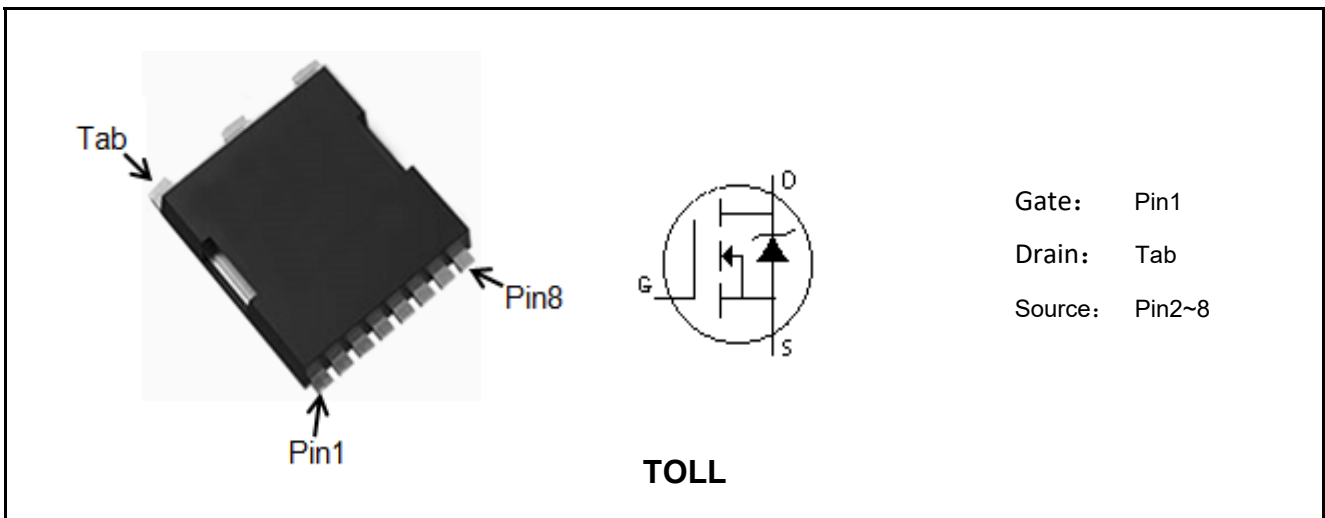

Marking	Package	Packaging	Min. package quantity
MT001R080SH	TOLL	Tape & Reel	2000



**■ Absolute Maximum Ratings (Tc=25°C unless otherwise noted)**

Parameter	Symbol	Ratings	Unit
Drain-Source Voltage	$V_{DS}$	80	V
Gate-Source Voltage	$V_{GS}$	±20	V
Continuous Drain Current Tc=25°C (Note 1)	$I_D$	460	A
Continuous Drain Current Tc=100°C (Note 1)		325	A
Drain Current-Pulsed (Note 1)	$I_{DM}$	1200	A
Total Dissipation	$P_D$	428	W
Junction Temperature	$T_j$	175	°C
Storage Temperature	$T_{stg}$	-55-175	°C
Single Pulse Avalanche Energy (Note 2)	$E_{AS}$	2250	mJ

Note: Using continuously under heavy loads (e.g. the application of high temperature/current/voltage and the significant change in temperature, etc.) may cause this product to decrease in the reliability significantly even if the operating conditions (i.e. operating temperature/current/voltage, etc.) are within the absolute maximum ratings.

**■ Thermal Characteristics**

Parameter	Symbol	Max	Unit
Maximum Junction-to-Case	$R_{\theta JC}$	0.35	°C/W
Maximum Junction-to-Ambient	$R_{\theta JA}$	40	°C/W

Note 1: Ensure that the channel temperature does not exceed 175°C.

Note 2:  $V_{DD}=50V$ ,  $T_{ch}= 25^{\circ}C$  (initial),  $L=0.5mH$ ,  $R_g=25\Omega$ .

Note: This transistor is sensitive to electrostatic discharge and should be handled with care.



**■ Electrical Characteristics (Tc=25°C unless otherwise noted)**

Parameter	Symbol	Test Condition	Min	Typ	Max	Unit
<b>Static Parameters</b>						
Drain-Source Breakdown Voltage	$BV_{DSS}$	$V_{GS}=0V, I_D=250\mu A$	80	-	-	V
Drain-Source Leakage Current	$I_{DSS}$	$V_{DS}=80V, V_{GS}=0V$	-	-	1	$\mu A$
Gate-Body Leakage Current	$I_{GSS}$	$V_{GS}=\pm 20V, V_{DS}=0V$	-	-	$\pm 100$	nA
Gate Threshold Voltage	$V_{GS(TH)}$	$V_{GS}=V_{DS}, I_D=250\mu A$	2.0	2.9	4.0	V
Drain-Source On Resistance	$R_{DS(ON)}$	$V_{GS}=10V, I_D=20A$	-	0.9	1	m $\Omega$
		Tj=125°C	-	1.5	-	
<b>Dynamic Characteristics</b>						
Input Capacitance	$C_{iss}$	$V_{DS}=35V, V_{GS}=0V,$ $f=1.0MHz$	-	19000	-	pF
Output Capacitance	$C_{oss}$		-	3800	-	pF
Reverse Transfer Capacitance	$C_{rss}$		-	600	-	pF
Gate Resistance	$R_g$	$V_{DS}=0V, V_{GS}=0V,$ $f=1.0MHz$	-	1.8	-	$\Omega$
<b>Switching Parameters</b>						
Turn-On Delay Time	$t_{d(on)}$	$V_{DS}=40V, I_D=20A,$ $V_{GS}=10V, R_G=3.9\Omega$	-	45	-	ns
Turn-On Rise Time	$t_r$		-	120	-	ns
Turn-Off Delay Time	$t_{d(off)}$		-	215	-	ns
Turn-Off Fall Time	$t_f$		-	125	-	ns
Total Gate Charge	$Q_g$	$V_{DS}=40V, I_D=20A,$ $V_{GS}=10V$	-	323	-	nC
Gate-Source Charge	$Q_{gs}$		-	73	-	nC
Gate-Drain Charge	$Q_{gd}$		-	84	-	nC
<b>Source-Drain Characteristics</b>						
Diode Forward Voltage	$V_{sd}$	$V_{GS}=0V, I_F=10A$	-	0.74	1.2	V
Reverse Recovery Time	$t_{rr}$	$V_R=40V, I_F=20A,$ $di/dt=100A/\mu s$	-	116	-	ns
Reverse Recovery Charge	$Q_{rr}$		-	330	-	nC

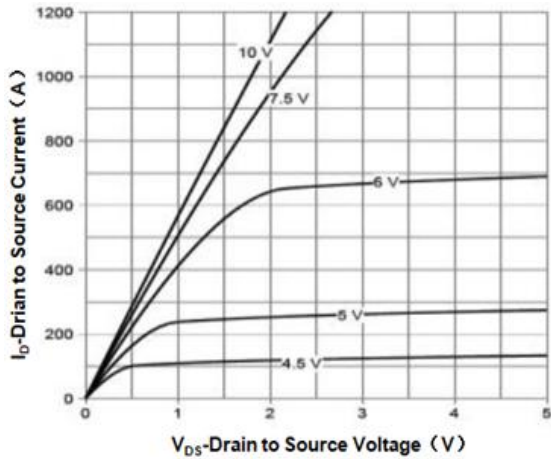
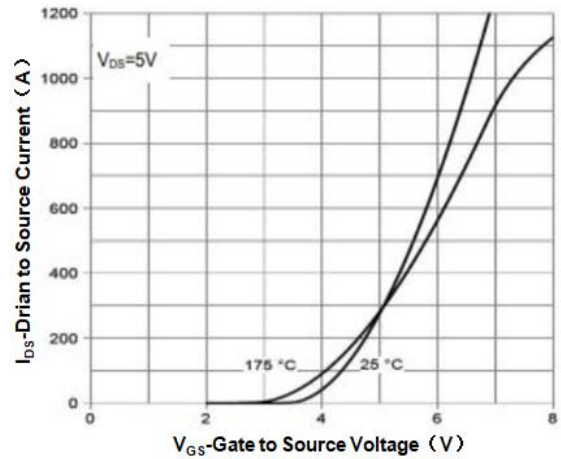
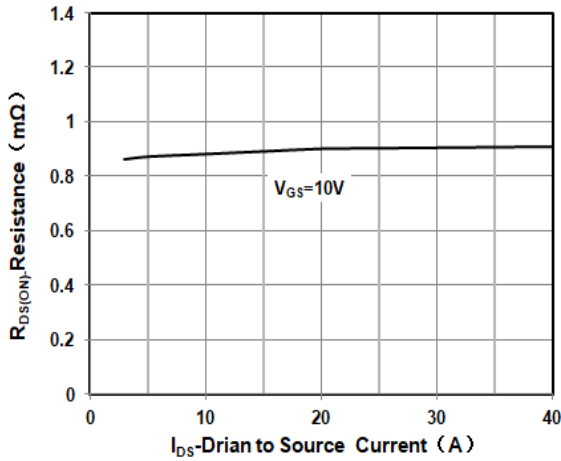
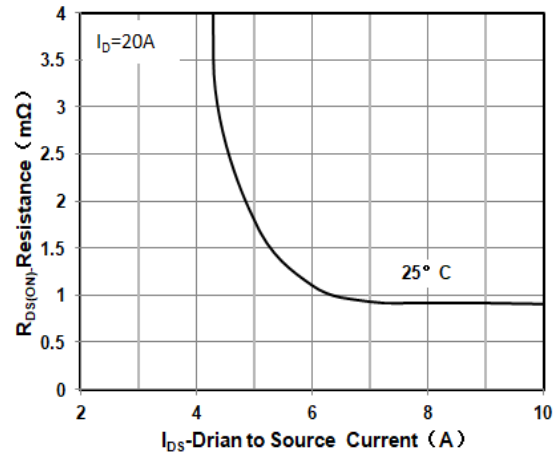
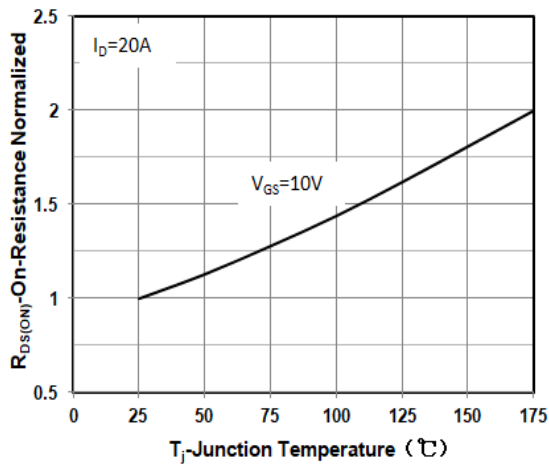
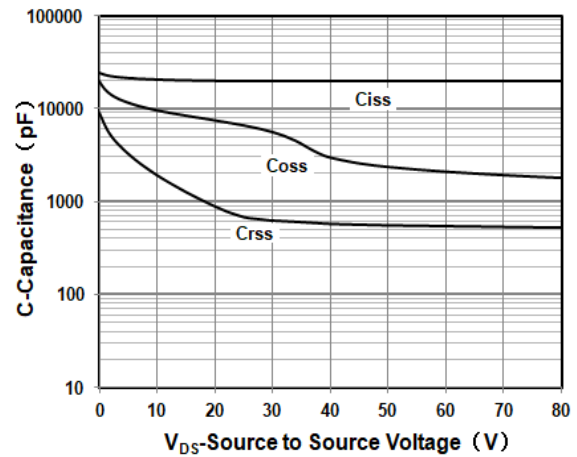

**■ Characteristics Curves**

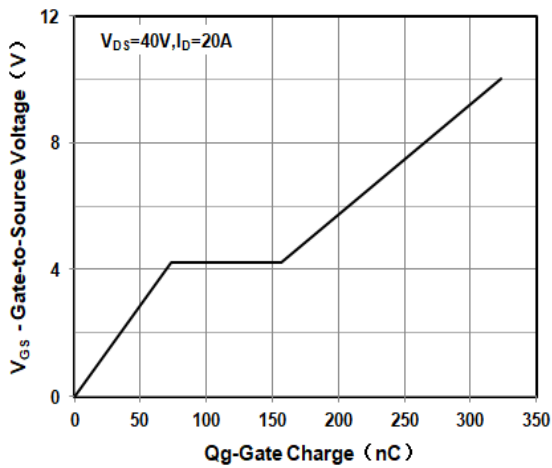
**Output Characterisics**

**Transfer Characterisics**

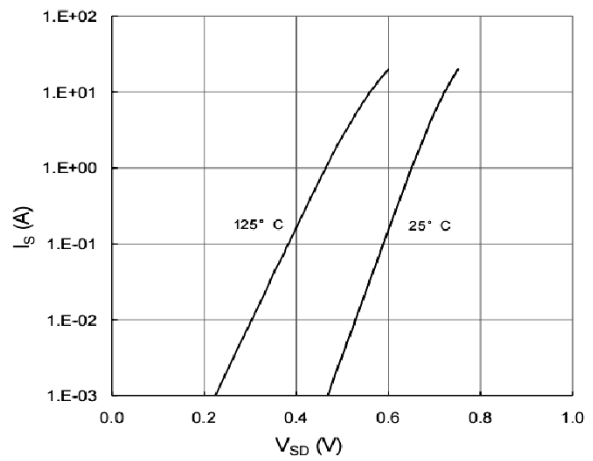
**On Resistance Vs Drain Current**

**On Resistance Vs Gate Source Voltage**

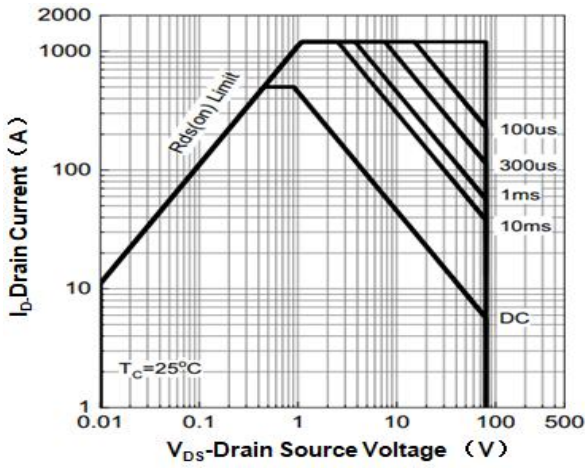
**Rdson-JunctionTemperature**

**Capacitance**

Gate Charge Waveform



Source-Drain Diode Forward Voltage



Maximum Safe Operating Area

Note : The above characteristics curves are presented for reference only and not guaranteed by production test, unless otherwise noted.

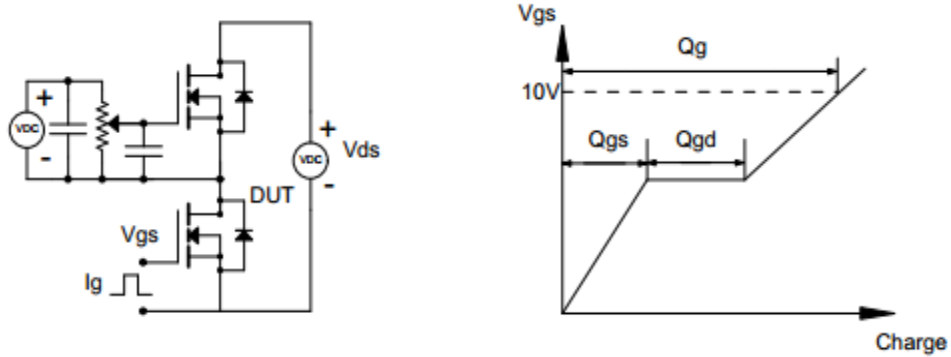
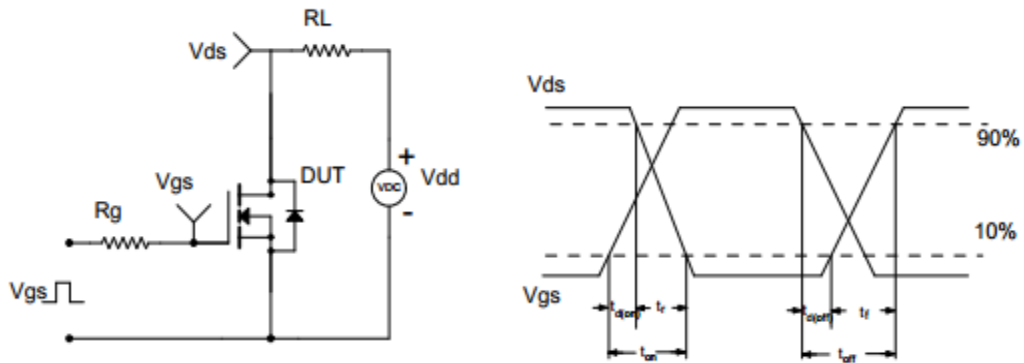
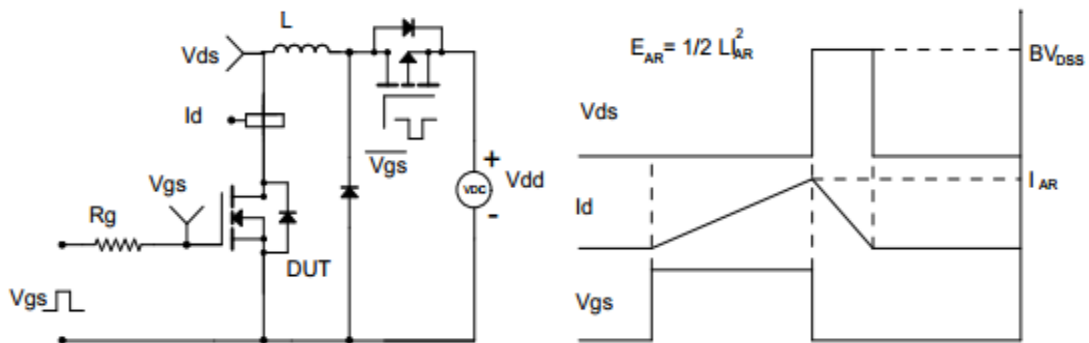

**■ Test Circuit & Waveform**
**Gate Charge Test Circuit & Waveform**

**Resistive Switching Test Circuit & Waveform**

**Unclamped Inductive Switching (UIS) Test Circuit & Waveform**

**■ TOLL Package Dimensions**

Unit: mm

Symbol	Min	Nom	Max	Symbol	Min	Nom	Max
A	2.25	2.3	2.35	e1		1.225	
A1	1.75	1.8	1.85	E	9.85	9.9	9.95
b	0.65	0.7	0.75	E1	8	8.1	8.2
b1	9.75	9.8	9.85	H	11.6	11.7	11.8
b2	0.7	0.75	0.8	H1		6.95	
c	0.45	0.5	0.55	K		3.1	
D	10.35	10.4	10.45	L	1.55	1.65	1.75
D1	11	11.1	11.2	L1	0.65	0.7	0.75
D2	3.25	3.3	3.35	L2	0.5	0.6	0.7
D4	4.5	4.55	4.6	Q		7.95	
e		1.2		$\theta$		10°	

