

MOSFETs Silicon 800V N-Channel MOS
■ Applications

- Power factor correction (PFC)
- Switched mode power supplies(SMPS)
- Uninterruptible Power Supply (UPS)

■ Features

- Multi-Epi process SJ-FET
- Low $R_{DS(ON)}$
- Ultra Low Gate Charge
- RoHS and Halogen-Free Compliant
- 100% UIS and RG Tested
- Fast-Recovery body diode
- Integrated Zener diode for high ESD robustness

■ Product Summary

$V_{DS} @ T_{j,max}$	850	V
I_D	50	A
$R_{DS(ON) ,Typ@10V}$	0.094	Ω
Q_g	95	nC

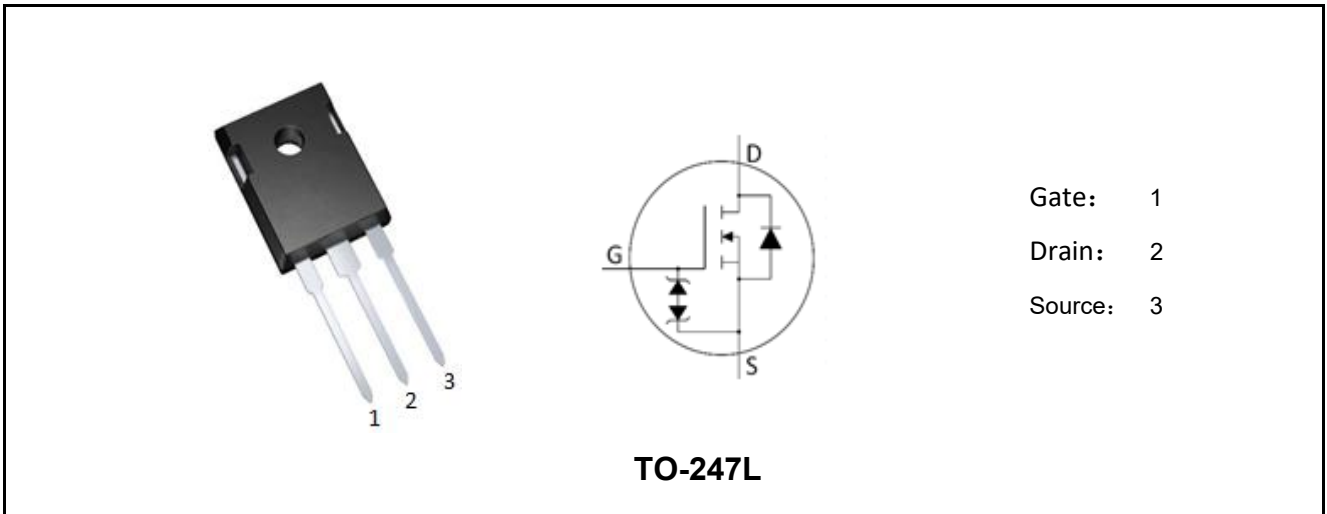

Marking	Package	Packaging	Min. package quantity
MSL110R80CFD2	TO-247L	Tube	450



■ Absolute Maximum Ratings (Tc=25°C unless otherwise noted)

Parameter	Symbol	Ratings	Unit
Drain-Source Voltage	V_{DS}	800	V
Gate-Source Voltage	V_{GS}	±30	V
Continuous Drain Current Tc=25°C (Note 1)	I_D	50	A
Continuous Drain Current Tc=100°C (Note 1)		30	
Drain Current-Pulsed (Note 1)	I_{DM}	125	A
Total Dissipation	P_D	470	W
Junction Temperature	T_j	150	°C
Storage Temperature	T_{stg}	-55-150	°C
Single Pulse Avalanche Energy (Note 2)	E_{AS}	200	mJ

Note: Using continuously under heavy loads (e.g. the application of high temperature/current/voltage and the significant change in temperature, etc.) may cause this product to decrease in the reliability significantly even if the operating conditions (i.e. operating temperature/current/voltage, etc.) are within the absolute maximum ratings.

■ Thermal Characteristics

Parameter	Symbol	Max	Unit
Maximum Junction-to-Case	$R_{\theta JC}$	0.27	°C/W
Maximum Junction-to-Ambient (Note 3)	$R_{\theta JA}$	40	°C/W

Note 1: Ensure that the channel temperature does not exceed 150°C.

Note 2: $V_{DD}=100V$, $T_{ch}=25^\circ C$ (initial), $L=0.5mH$, $I_{AS}=25A$, $R_g=25\Omega$.

Note: This transistor is sensitive to electrostatic discharge and should be handled with care.



■ Electrical Characteristics (Tc=25°C unless otherwise noted)

Parameter	Symbol	Test Condition	Min	Typ	Max	Unit
Static Parameters						
Drain-Source Breakdown Voltage	BV _{DSS}	V _{GS} =0V, I _D =250uA	800	-	-	V
		T _J =150°C	850	-	-	
Drain-Source Leakage Current	I _{DSS}	V _{DS} =800V, V _{GS} =0V	-	-	5	uA
Gate-Body Leakage Current	I _{GSS}	V _{GS} =±20V, V _{DS} =0V	-	-	±1	uA
Gate Threshold Voltage	V _{GS(TH)}	V _{GS} =V _{DS} , I _D =250uA	3	4	5	V
Drain-Source On Resistance	R _{DS(ON)}	V _{GS} =10V, I _D =25A	-	0.094	0.11	Ω
		T _J =150°C	-	0.22	-	
Dynamic Characteristics						
Input Capacitance	C _{iss}	V _{DS} =25V, V _{GS} =0V, f=1.0MHz	-	4750	-	pF
Output Capacitance	C _{oss}		-	2000	-	pF
Reverse Transfer Capacitance	C _{rss}		-	52	-	pF
Gate Resistance	R _g	V _{DS} =0V, V _{GS} =0V, f=1.0MHz	-	2.2	-	Ω
Switching Paramters						
Turn-On Delay Time	t _{d(on)}	V _{DS} =400V, I _D =25A, V _{GS} =10V, R _G =1Ω	-	27	-	ns
Turn-On Rise Time	t _r		-	30	-	ns
Turn-Off Delay Time	t _{d(off)}		-	70	-	ns
Turn-Off Fall Time	t _f		-	15	-	ns
Total Gate Charge	Q _g	V _{DS} =400V, I _D =25A, V _{GS} =10V	-	95	-	nC
Gate-Source Charge	Q _{gs}		-	30	-	nC
Gate-Drain Charge	Q _{gd}		-	30	-	nC
Source-Drain Characteristics						
Max. Diode Forward Current	I _S		-	-	50	A
Max. Pulsed Forward Current	I _{SM}		-	-	125	A
Diode Forward Voltage	V _{sd}	V _{GS} =0V, I _S =25A	-	0.9	1.5	V
Reverse Recovery Time	t _{rr}	V _R =600V, I _F =25A, di/dt=100A/us	-	190	-	ns
Reverse Recovery Charge	Q _{rr}		-	2.0	-	μC

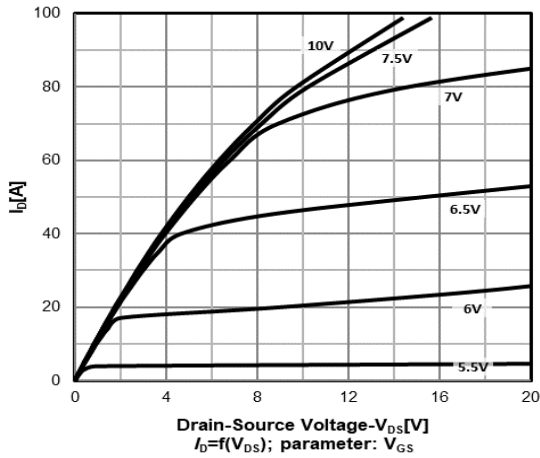
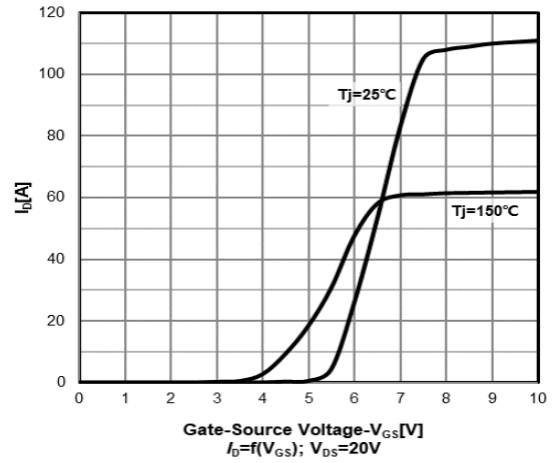
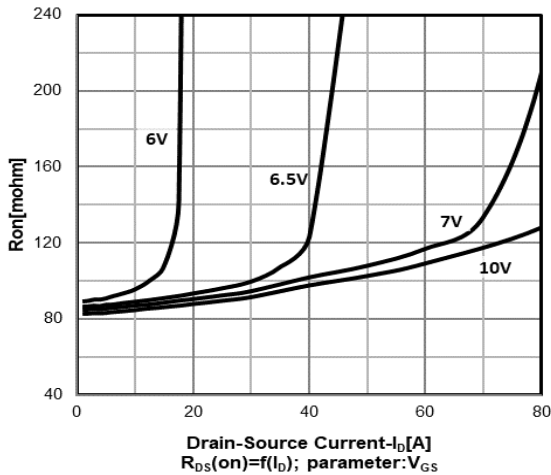
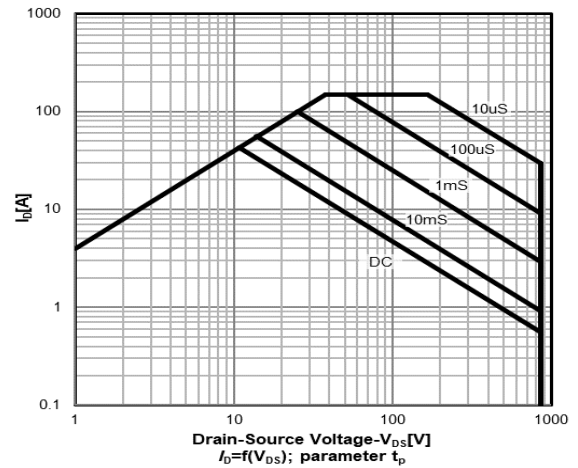
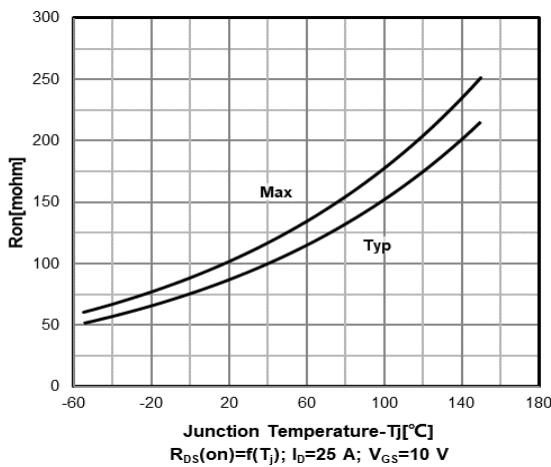
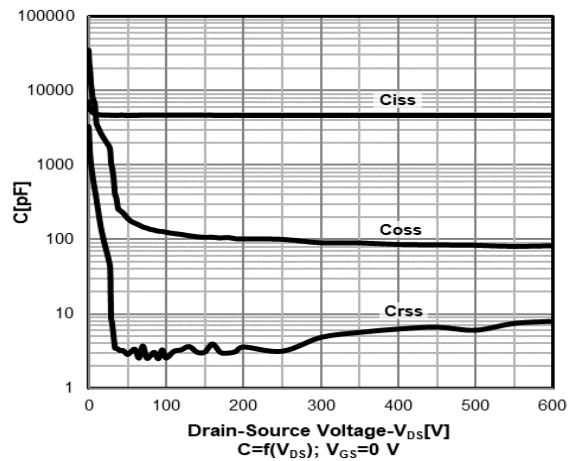

■ Characteristics Curves

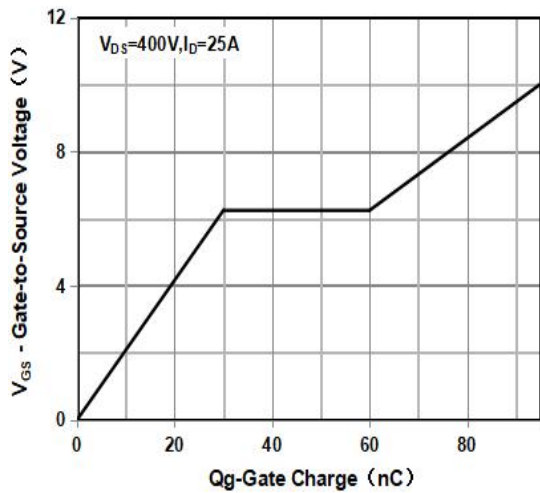
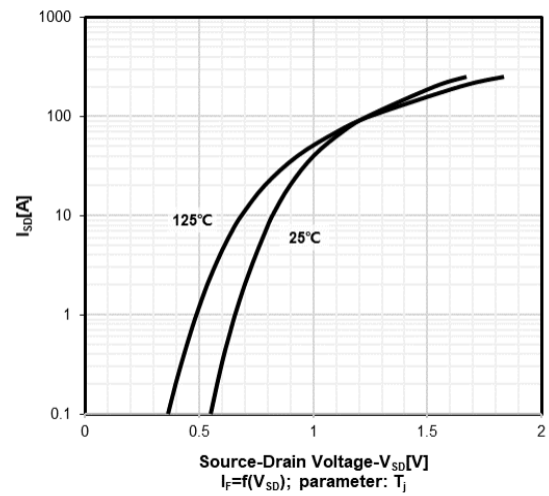
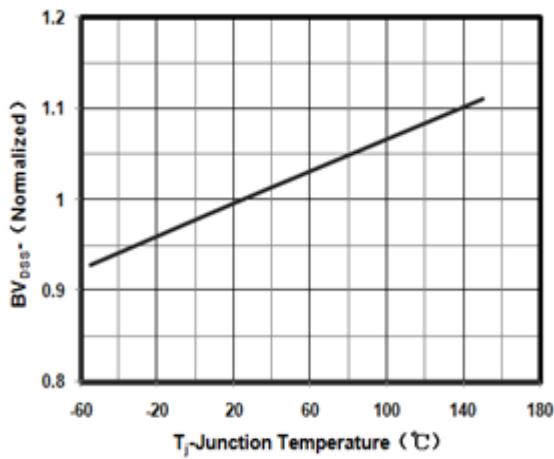
Output Characteristics

Transfer Characteristics

On Resistance Vs Drain Current

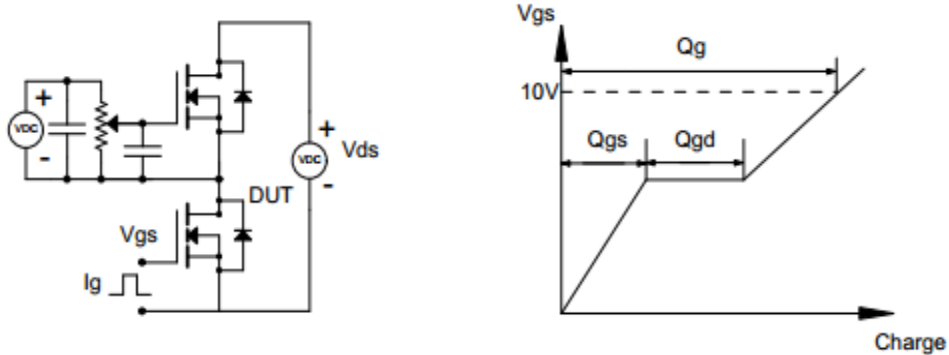
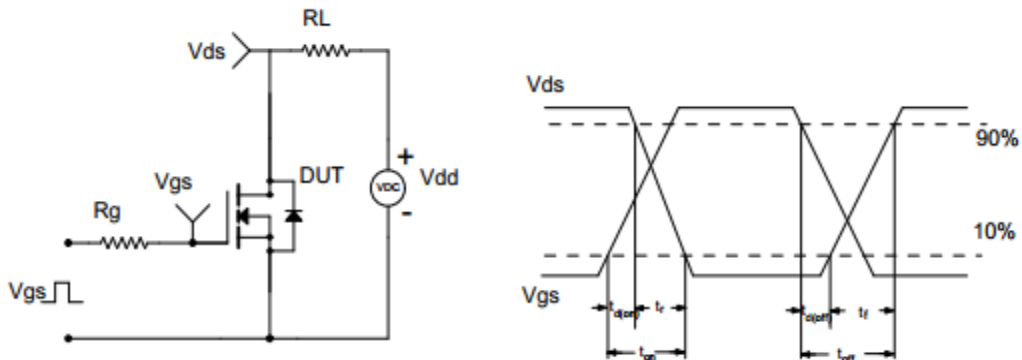
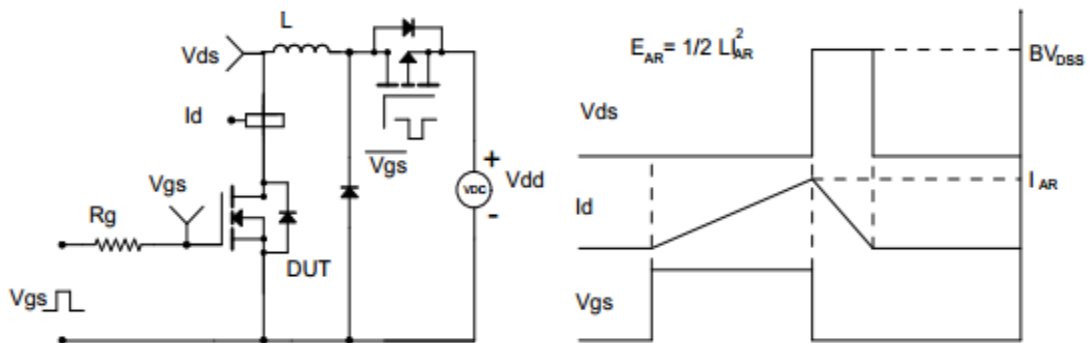
Maximum Safe Operating Area

Rdson-Junction Temperature

Capacitance



Gate Charge Waveform

Source-Drain Diode Forward Voltage

Breakdown Voltage Vs Junction Temperature

Note : The above characteristics curves are presented for reference only and not guaranteed by production test, unless otherwise noted.



■ Test Circuit & Waveform
Gate Charge Test Circuit & Waveform

Resistive Switching Test Circuit & Waveform

Unclamped Inductive Switching (UIS) Test Circuit & Waveform

■ TO-247L Package Dimensions

Unit: mm

Symbol	Min	Nom	Max	Symbol	Min	Nom	Max
A	4.80		5.20	E1	13.00		13.60
A1	2.20	2.40	2.60	E2	5.00		5.50
A2	1.85		2.15	E3	1.90		2.60
b	1.07		1.33	e		5.44	
b2	1.90		2.16	L	19.30		19.90
b4	2.90		3.20	L1	3.75	3.95	4.15
c	0.52		0.68	ΦP	3.40		3.80
D	20.70		21.30	ΦP1	7.00		7.40
D1	16.15		16.95	S	6.04	6.15	6.30
E	15.50		16.10				

