

MOSFETs Silicon 80V N-Channel MOS
■ Applications

- Synchronus Rectification
- Industrial and Motor Drive
- DC/DC and AC/DC Converters
- Power Tools

■ Features

- High-Speed Switching
- Low $R_{DS(ON)}$
- Good stability and uniformity with high EAS
- RoHS and Halogen-Free Compliant
- 100% UIS and RG Tested

■ Product Summary

V_{DS}	80	V
I_D	80	A
$R_{DS(ON),TYP@10V}$	10	m Ω
Q_g	110	nC

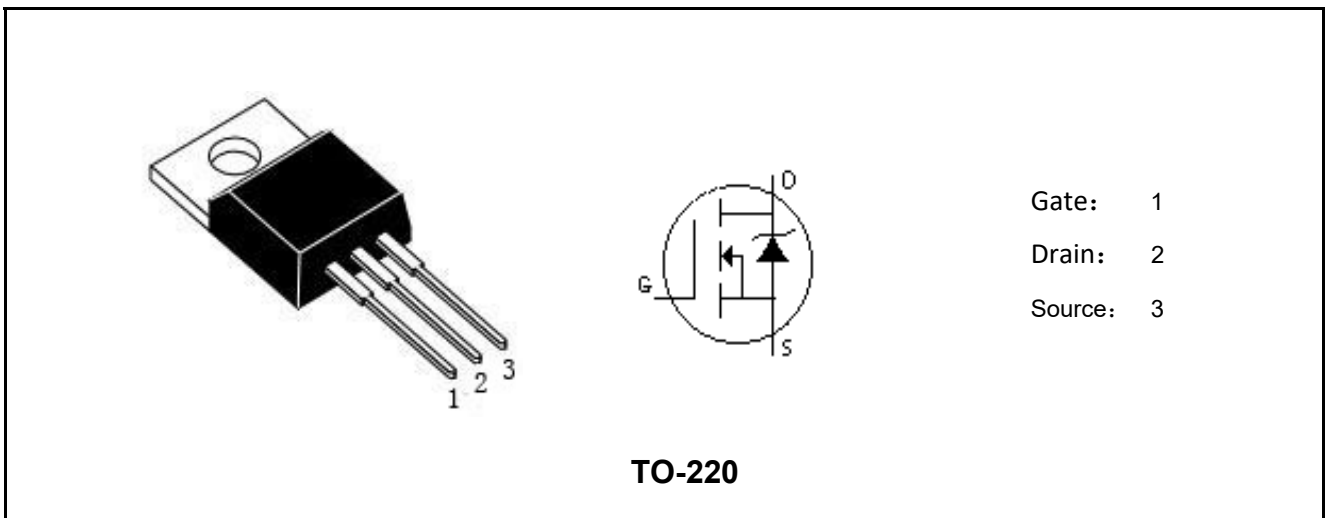

Marking	Package	Packaging	Min. package quantity
MC012R080PH	TO-220	Tube	1000



■ Absolute Maximum Ratings (Tc=25°C unless otherwise noted)

Parameter	Symbol	Ratings	Unit
Drain-Source Voltage	V_{DS}	80	V
Gate-Source Voltage	V_{GS}	±20	V
Continuous Drain Current Tc=25°C (Note 1)	I_D	80	A
Continuous Drain Current Tc=100°C (Note 1)		50	A
Drain Current-Pulsed (Note 1)	I_{DM}	300	A
Total Dissipation	P_D	196	W
Junction Temperature	T_j	150	°C
Storage Temperature	T_{stg}	-55-150	°C
Single Pulse Avalanche Energy (Note 2)	E_{AS}	1300	mJ

Note: Using continuously under heavy loads (e.g. the application of high temperature/current/voltage and the significant change in temperature, etc.) may cause this product to decrease in the reliability significantly even if the operating conditions (i.e. operating temperature/current/voltage, etc.) are within the absolute maximum ratings.

■ Thermal Characteristics

Parameter	Symbol	Max	Unit
Maximum Junction-to-Case	$R_{\theta JC}$	0.65	°C/W
Maximum Junction-to-Ambient	$R_{\theta JA}$	60	°C/W

Note 1: Ensure that the channel temperature does not exceed 150°C.

Note 2: $V_{DD}=50V$, $T_{ch}=25^\circ C$ (initial), $L=0.5mH$, $R_g=25\Omega$.

Note: This transistor is sensitive to electrostatic discharge and should be handled with care.



■ Electrical Characteristics (Tc=25°C unless otherwise noted)

Parameter	Symbol	Test Condition	Min	Typ	Max	Unit
Static Parameters						
Drain-Source Breakdown Voltage	BV_{DSS}	$V_{GS}=0V, I_D=250\mu A$	80	-	-	V
Drain-Source Leakage Current	I_{DSS}	$V_{DS}=80V, V_{GS}=0V$	-	-	1	μA
Gate-Body Leakage Current	I_{GSS}	$V_{GS}=\pm 20V, V_{DS}=0V$	-	-	± 100	nA
Gate Threshold Voltage	$V_{GS(TH)}$	$V_{GS}=V_{DS}, I_D=250\mu A$	2	3	4	V
Drain-Source On Resistance	$R_{DS(ON)}$	$V_{GS}=10V, I_D=20A$	-	10	12	m Ω
		Tj=125°C	-	16	-	
Dynamic Characteristics						
Input Capacitance	C_{iss}	$V_{DS}=35V, V_{GS}=0V,$ $f=1.0MHz$	-	2600	-	pF
Output Capacitance	C_{oss}		-	580	-	pF
Reverse Transfer Capacitance	C_{rss}		-	220	-	pF
Gate Resistance	R_g	$V_{DS}=0V, V_{GS}=0V,$ $f=1.0MHz$	-	0.5	-	Ω
Switching Parameters						
Turn-On Delay Time	$t_{d(on)}$	$V_{DS}=40V, I_D=30A,$ $V_{GS}=10V, R_G=25\Omega$	-	40	-	ns
Turn-On Rise Time	t_r		-	110	-	ns
Turn-Off Delay Time	$t_{d(off)}$		-	160	-	ns
Turn-Off Fall Time	t_f		-	90	-	ns
Total Gate Charge	Q_g	$V_{DS}=50V, I_D=20A,$ $V_{GS}=10V$	-	110	-	nC
Gate-Source Charge	Q_{gs}		-	18	-	nC
Gate-Drain Charge	Q_{gd}		-	50	-	nC
Source-Drain Characteristics						
Diode Forward Voltage	V_{sd}	$V_{GS}=0V, I_S=10A$	-	0.78	1.2	V
Reverse Recovery Time	t_{rr}	$V_R=50V, I_F=20A,$ $di/dt=100A/\mu s$	-	110	-	ns
Reverse Recovery Charge	Q_{rr}		-	0.45	-	μC

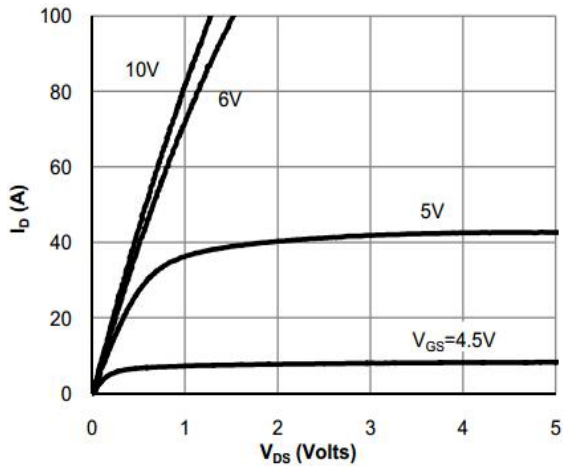
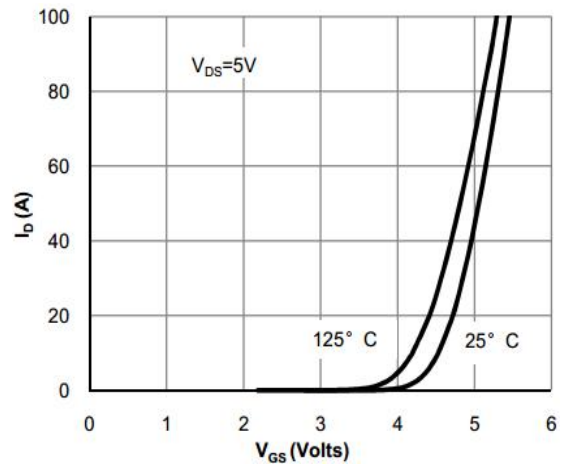
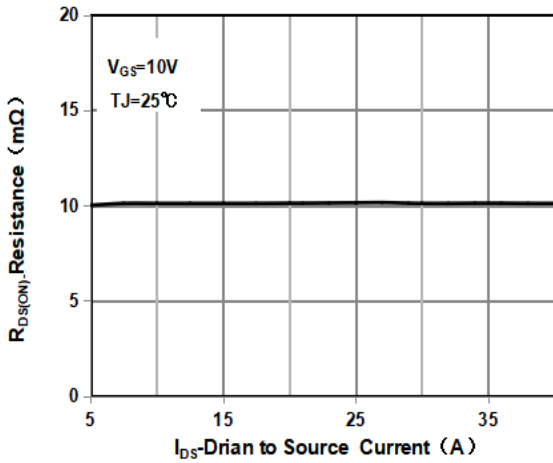
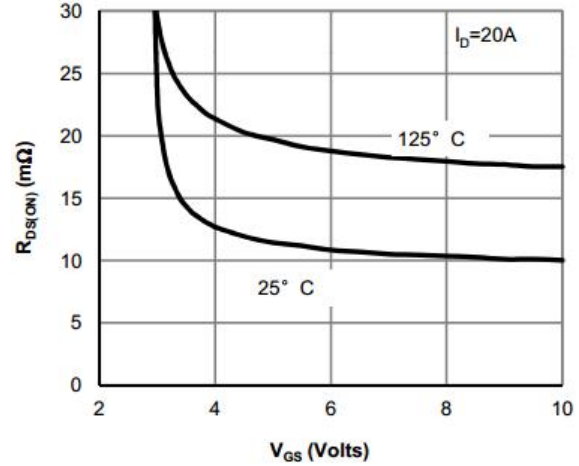
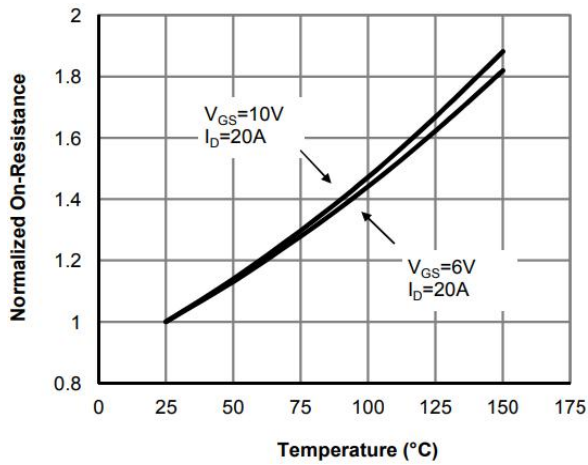
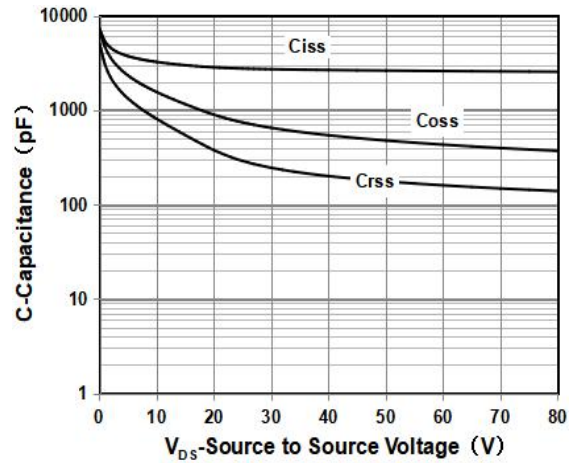

■ Characteristics Curves

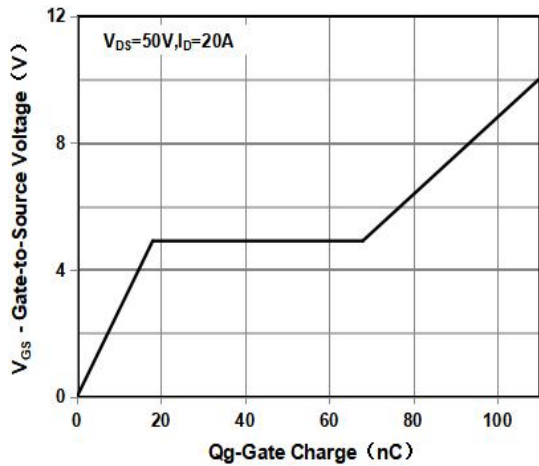
Output Characteristics

Transfer Characteristics

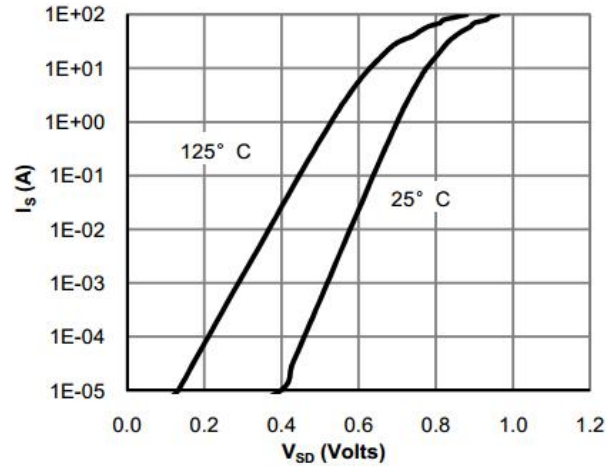
On Resistance Vs Drain Current

On Resistance Vs Gate Source Voltage

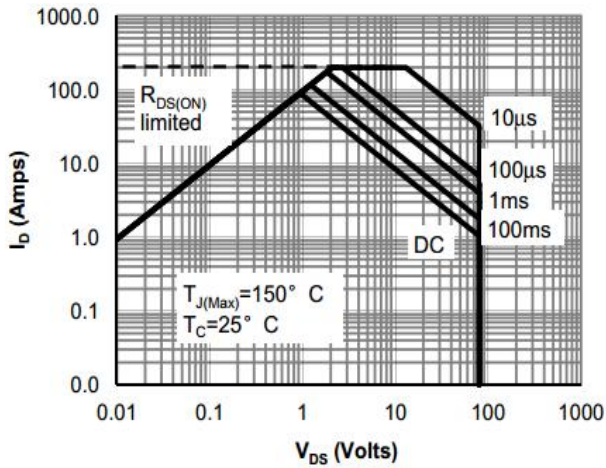
Rdson-Junction Temperature

Capacitance

Gate Charge Waveform



Source-Drain Diode Forward Voltage



Maximum Safe Operating Area

Note : The above characteristics curves are presented for reference only and not guaranteed by production test, unless otherwise noted.

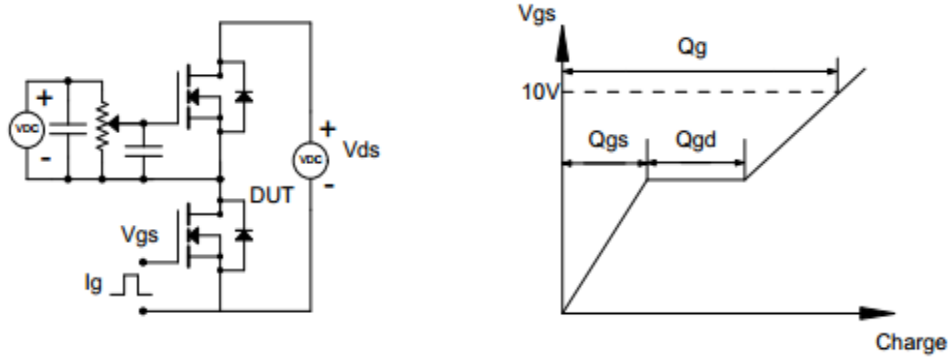
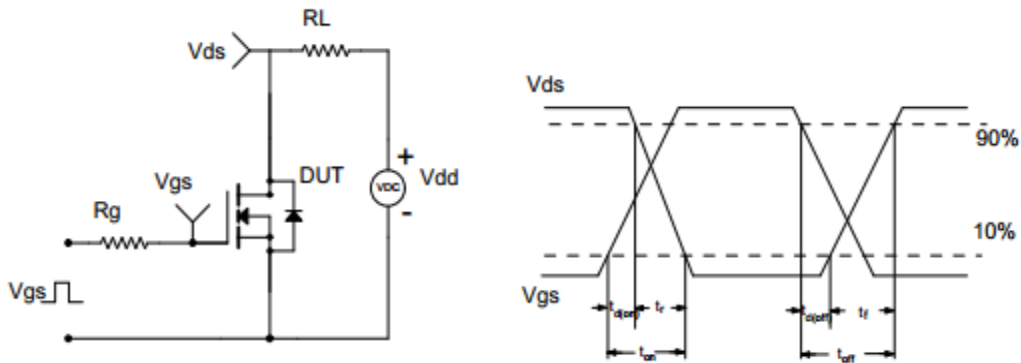
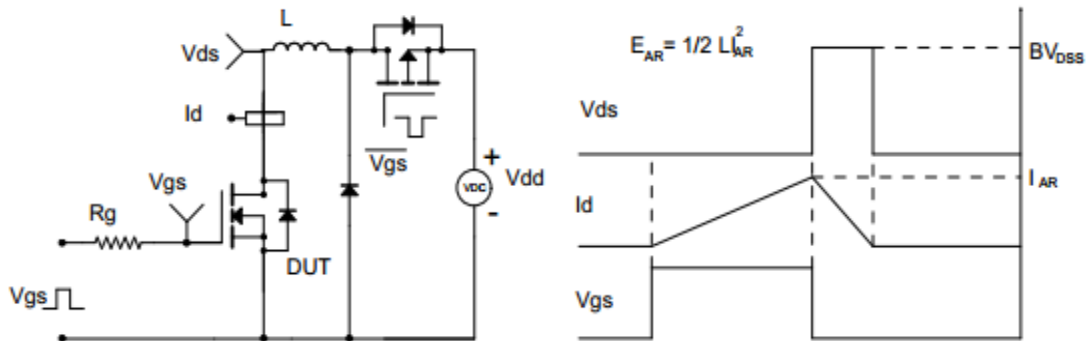

■ Test Circuit & Waveform
Gate Charge Test Circuit & Waveform

Resistive Switching Test Circuit & Waveform

Unclamped Inductive Switching (UIS) Test Circuit & Waveform

TO-220 Package Dimensions

Unit: mm

Symbol	Min	Nom	Max	Symbol	Min	Nom	Max
A	4.00		4.80	e	2.44	2.54	2.64
B	1.20		1.40	F	1.10		1.40
B1	1.00		1.40	L	12.50		14.50
b1	0.75		0.95	L1	3.00	3.50	4.00
c	0.40		0.55	ΦP	3.70	3.80	3.90
D	15.00		16.50	Q	2.50		3.00
D1	5.90		6.90	Q1	2.00		2.90
E	9.90		10.70	Y	8.02	8.12	8.22

