

» **Applications**

- Synchronus Rectification
- Industrial and Motor Drive
- DC/DC and AC/DC Converters
- Power Tools

» **Product Summary**

V_{DS}	30	V
I_D	185	A
$R_{DS(ON), Typ@10V}$	1.0	m Ω
$R_{DS(ON), Typ@4.5V}$	1.5	m Ω
Q_g	50	nC

» **Features**

- High-Speed Switching
- Low $R_{DS(ON)}$
- Enhanced Body diode dv/dt capability
- Enhanced Avalanche Ruggedness
- 100% UIS and RG Tested



DFN5x6

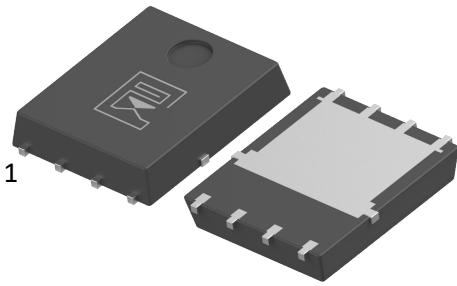

S	1	●	8	D
S	2		7	D
S	3		6	D
G	4		5	D

Gate: 4

Drain: 5-8

Source: 1-3

» **Package Marking and Ordering Information**

Ordering code	Marking	Package	Packaging	Min. package quantity
MDG1D5R030SL	MDG1D5R030SL	DFN5x6	Tape & Reel	5000

»» Absolute Maximum Ratings (Tc=25°C unless otherwise noted)

Parameter	Symbol	Ratings	Unit
Drain-Source Voltage	V_{DS}	30	V
Gate-Source Voltage	V_{GS}	±20	V
Continuous Drain Current Tc=25°C (Note 1)	I_D	185	A
Continuous Drain Current Tc=100°C (Note 1)		115	A
Drain Current-Pulsed (Note 1)	I_{DM}	640	A
Total Dissipation	P_D	78	W
Junction Temperature	T_j	150	°C
Storage Temperature	T_{stg}	-55-150	°C
Single Pulse Avalanche Energy (Note 2)	E_{AS}	650	mJ

Note: Using continuously under heavy loads (e.g. the application of high temperature/current/voltage and the significant change in temperature, etc.) may cause this product to decrease in the reliability significantly even if the operating conditions (i.e. operating temperature/current/voltage, etc.) are within the absolute maximum ratings.

»» Thermal Characteristics

Parameter	Symbol	Max	Unit
Maximum Junction-to-Case	$R_{\theta JC}$	1.6	°C/W
Maximum Junction-to-Ambient	$R_{\theta JA}$	60	°C/W

Note 1: Ensure that the channel temperature does not exceed 150°C.

Note 2: $V_{DD}=30V$, $T_{ch}= 25^\circ C$ (initial), $L=0.5mH$, $R_g=25\Omega$.

Note: This transistor is sensitive to electrostatic discharge and should be handled with care.

Electrical Characteristics (Tc=25°C unless otherwise noted)

Parameter	Symbol	Test Condition	Min	Typ	Max	Unit
Static Parameters						
Drain-Source Breakdown Voltage	BV_{DSS}	$V_{GS}=0V, I_D=250\mu A$	30	-	-	V
Drain-Source Leakage Current	I_{DSS}	$V_{DS}=30V, V_{GS}=0V$	-	-	1	μA
Gate-Body Leakage Current	I_{GSS}	$V_{GS}=\pm 20V, V_{DS}=0V$	-	-	± 100	nA
Gate Threshold Voltage	$V_{GS(TH)}$	$V_{GS}=V_{DS}, I_D=250\mu A$	1.2	1.6	2.2	V
Drain-Source On Resistance	$R_{DS(ON)}$	$V_{GS}=4.5V, I_D=15A$	-	1.5	1.9	m Ω
		$T_j=125^\circ C$	-	2.0	-	
		$V_{GS}=10V, I_D=20A$	-	1.0	1.5	
		$T_j=125^\circ C$	-	1.3	-	
Dynamic Characteristics						
Input Capacitance	C_{iss}	$V_{DS}=15V, V_{GS}=0V,$ $f=1.0MHz$	-	3450	-	pF
Output Capacitance	C_{oss}		-	1300	-	pF
Reverse Transfer Capacitance	C_{rss}		-	80	-	pF
Gate Resistance	R_g	$V_{DS}=0V, V_{GS}=0V,$ $f=1.0MHz$	-	1.6	-	Ω
Switching Paramters						
Turn-On Delay Time	$t_{d(on)}$	$V_{DS}=15V, I_D=30A,$ $V_{GS}=10V, R_G=3\Omega$	-	10	-	ns
Turn-On Rise Time	t_r		-	31	-	ns
Turn-Off Delay Time	$t_{d(off)}$		-	55	-	ns
Turn-Off Fall Time	t_f		-	16	-	ns
Total Gate Charge	Q_g	$V_{DS}=15V, I_D=60A,$ $V_{GS}=10V$	-	50	-	nC
Gate-Source Charge	Q_{gs}		-	12	-	nC
Gate-Drain Charge	Q_{gd}		-	6	-	nC
Source-Drain Characteristics						
Diode Forward Voltage	V_{sd}	$V_{GS}=0V, I_S=60A$	-	0.8	1.4	V
Reverse Recovery Time	t_{rr}	$V_R=15V, I_F=60A,$ $di/dt=100A/\mu s$	-	50	-	ns
Reverse Recovery Charge	Q_{rr}		-	60	-	nC



Characteristics Curves

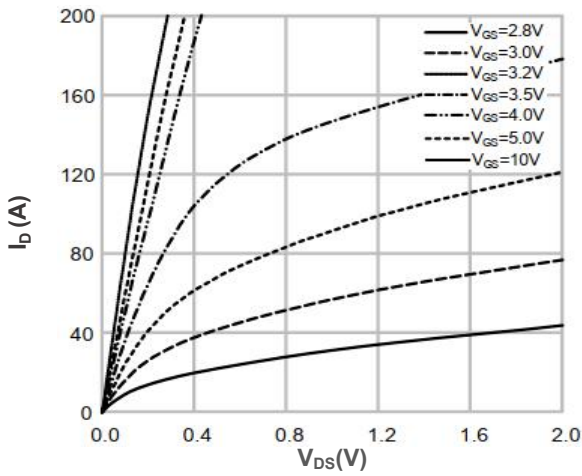

Output Characteristics

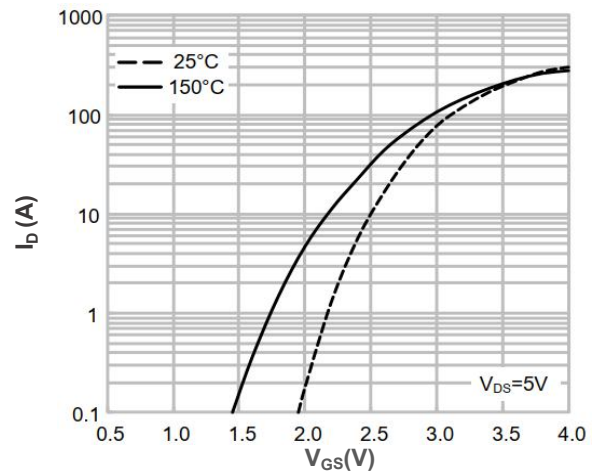

Transfer Characteristics

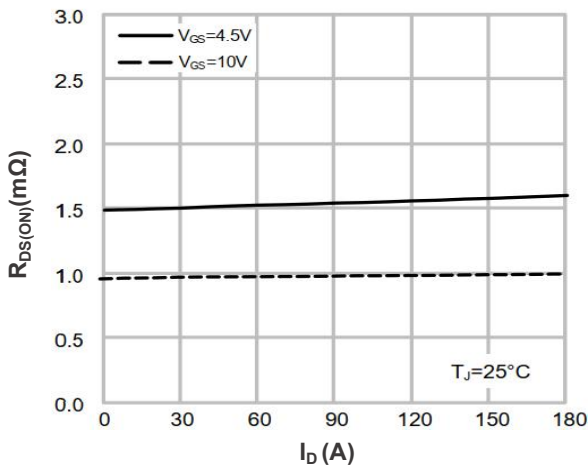

On Resistance Vs Drain Current

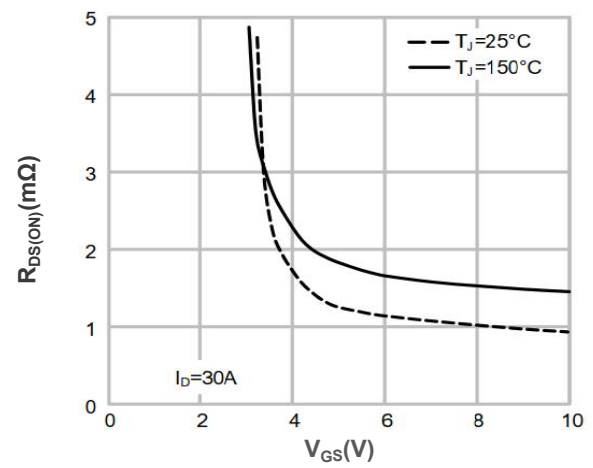

On Resistance Vs Gate Source Voltage

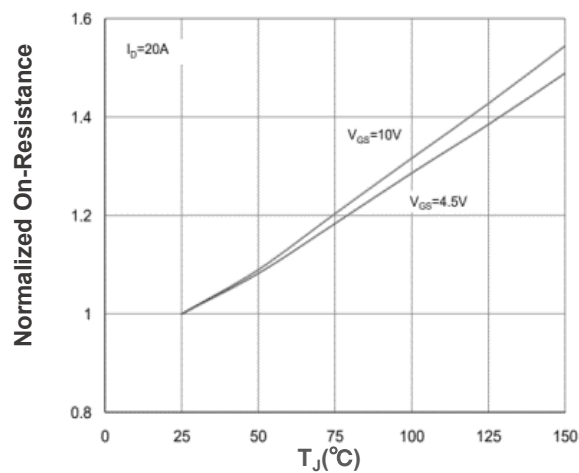

Rdson-JunctionTemperature

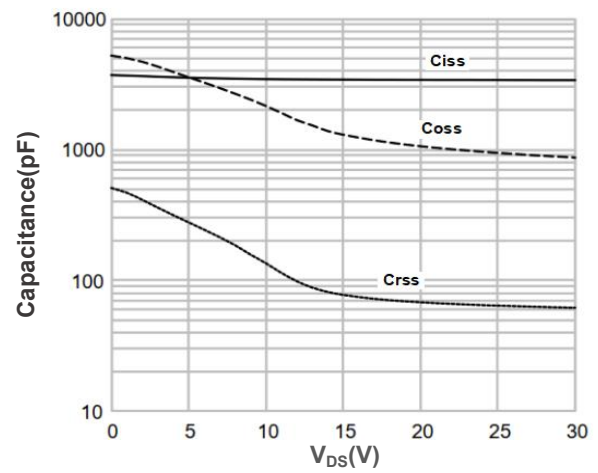

Capacitance

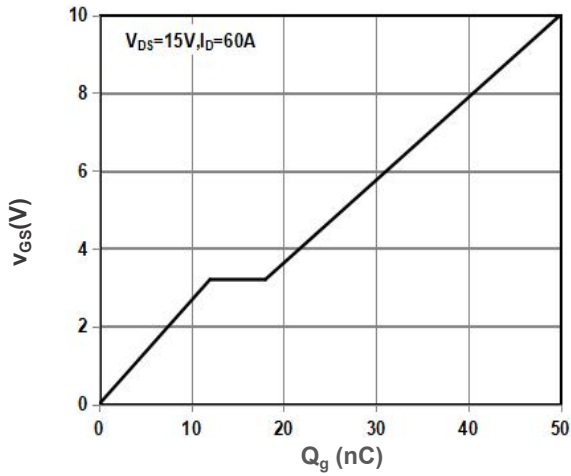

Gate Charge Waveform

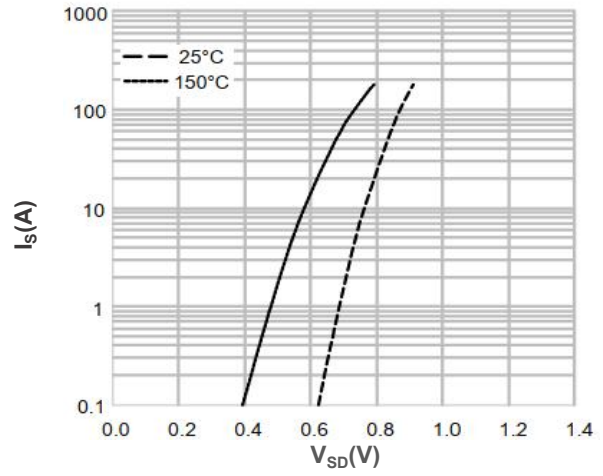

Source-Drain Diode Forward Voltage

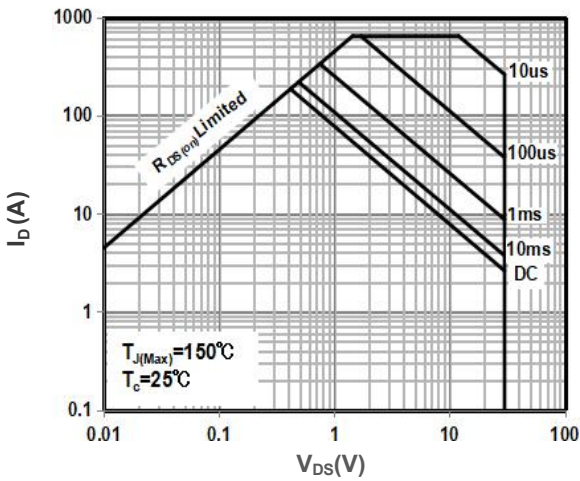

Maximum Safe Operating Area

Note : The above characteristics curves are presented for reference only and not guaranteed by production test, unless otherwise noted.



Test Circuit & Waveform

Gate Charge Test Circuit & Waveform

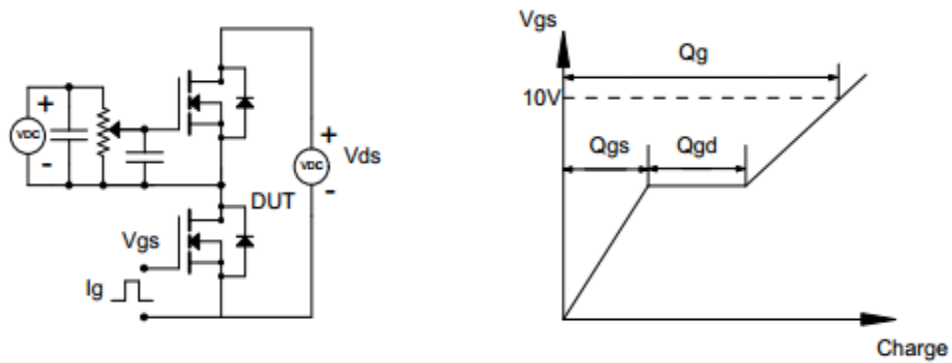

Resistive Switching Test Circuit & Waveform

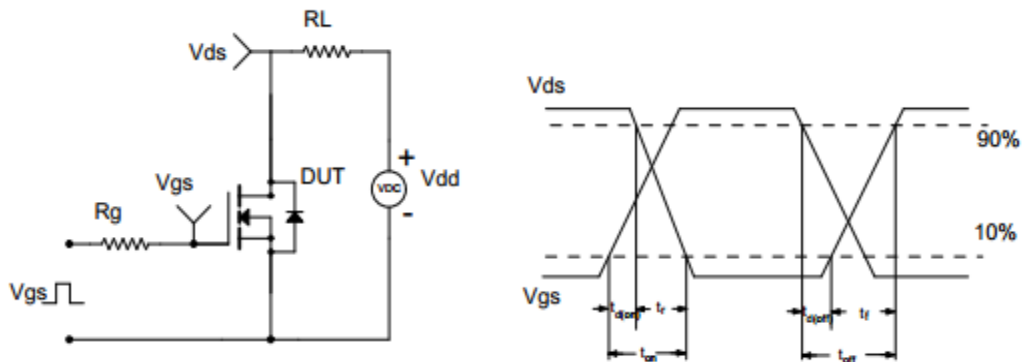

Unclamped Inductive Switching (UIS) Test Circuit & Waveform

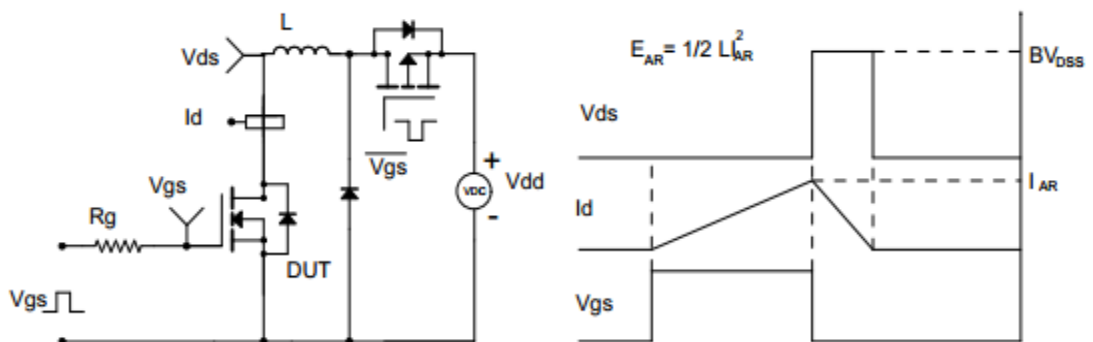



» DFN5x6 Package Dimensions

Unit: mm

Symbol	Min	Nom	Max	Symbol	Min	Nom	Max
A	0.90		1.10	k	1.15		1.35
A3	0.15		0.30	b	0.20		0.40
D	4.90		5.10	e	1.15		1.35
D1	3.90		4.10	L	0.50		0.65
D2	4.75		5.05	L1	0.43		0.55
E	5.85		6.15	H	0.55		0.68
E1	3.35		3.55	θ	8°		12°
E2	5.55		5.85				

