

Applications

- Synchronous Rectification
- Industrial and Motor Drive
- DC/DC and AC/DC Converters
- Power Tools

Product Summary

V_{DS}	40	V
I_D	156	A
$R_{DS(ON), Typ@10V}$	1.7	m Ω
$R_{DS(ON), Typ@4.5V}$	2.3	m Ω
Q_g	54	nC

Features

- High-Speed Switching
- Low $R_{DS(ON)}$
- Enhanced Body diode dv/dt capability
- Enhanced Avalanche Ruggedness
- 100% UIS and RG Tested



TOLT

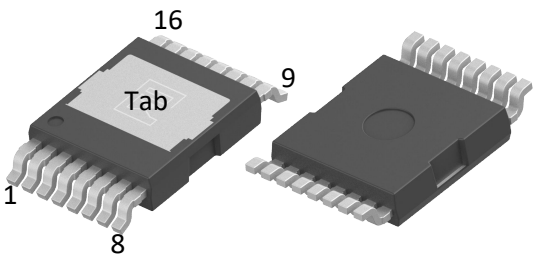

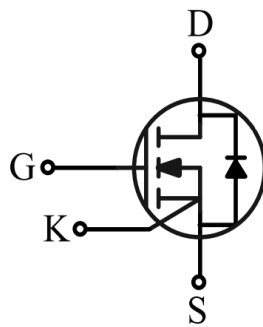

Gate: Pin8
Drain: Tab, Pin9-16
Source: Pin1-6
Driver Source: Pin7

Package Marking and Ordering Information

Ordering code	Marking	Package	Packaging	Min. package quantity
MTT002R040SL	MTT002R040SL	TOLT	Tape & Reel	1200

» Absolute Maximum Ratings (Tc=25°C unless otherwise noted)

Parameter	Symbol	Ratings	Unit
Drain-Source Voltage	V_{DS}	40	V
Gate-Source Voltage	V_{GS}	±20	V
Continuous Drain Current Tc=25°C (Note 1)	I_D	156	A
Continuous Drain Current Tc=100°C (Note 1)		100	A
Drain Current-Pulsed (Note 1)	I_{DM}	600	A
Total Dissipation	P_D	73	W
Junction Temperature	T_j	150	°C
Storage Temperature	T_{stg}	-55-150	°C
Single Pulse Avalanche Energy (Note 2)	E_{AS}	500	mJ

Note: Using continuously under heavy loads (e.g. the application of high temperature/current/voltage and the significant change in temperature, etc.) may cause this product to decrease in the reliability significantly even if the operating conditions (i.e. operating temperature/current/voltage, etc.) are within the absolute maximum ratings.

» Thermal Characteristics

Parameter	Symbol	Max	Unit
Maximum Junction-to-Case	$R_{\theta JC}$	1.7	°C/W
Maximum Junction-to-Ambient	$R_{\theta JA}$	40	°C/W

Note 1: Ensure that the channel temperature does not exceed 150°C.

Note 2: $V_{DD}=40V$, $T_{ch}= 25^{\circ}C$ (initial), $L=0.5mH$, $R_g=25\Omega$.

Note: This transistor is sensitive to electrostatic discharge and should be handled with care.



Electrical Characteristics (Tc=25°C unless otherwise noted)

Parameter	Symbol	Test Condition	Min	Typ	Max	Unit
Static Parameters						
Drain-Source Breakdown Voltage	BV_{DSS}	$V_{GS}=0V, I_D=250\mu A$	40	-	-	V
Drain-Source Leakage Current	I_{DSS}	$V_{DS}=40V, V_{GS}=0V$	-	-	1	μA
Gate-Body Leakage Current	I_{GSS}	$V_{GS}=\pm 20V, V_{DS}=0V$	-	-	± 100	nA
Gate Threshold Voltage	$V_{GS(TH)}$	$V_{GS}=V_{DS}, I_D=250\mu A$	1.0	1.8	3.0	V
Drain-Source On Resistance	$R_{DS(ON)}$	$V_{GS}=4.5V, I_D=15A$	-	2.3	2.7	m Ω
		Tj=125°C	-	3.3	-	
		$V_{GS}=10V, I_D=20A$	-	1.7	2.0	m Ω
		Tj=125°C	-	2.4	-	
Dynamic Characteristics						
Input Capacitance	C_{iss}	$V_{DS}=15V, V_{GS}=0V,$ $f=1.0MHz$	-	3348	-	pF
Output Capacitance	C_{oss}		-	2063	-	pF
Reverse Transfer Capacitance	C_{rss}		-	55	-	pF
Gate Resistance	R_g	$V_{DS}=0V, V_{GS}=0V,$ $f=1.0MHz$	-	2.1	-	Ω
Switching Paramters						
Turn-On Delay Time	$t_{d(on)}$	$V_{DS}=20V, I_D=20A,$ $V_{GS}=10V, R_G=10\Omega$	-	28	-	ns
Turn-On Rise Time	t_r		-	15	-	ns
Turn-Off Delay Time	$t_{d(off)}$		-	75	-	ns
Turn-Off Rise Time	t_f		-	18	-	ns
Total Gate Charge	Q_g	$V_{DS}=32V, I_D=20A,$ $V_{GS}=10V$	-	54	-	nC
Gate-Source Charge	Q_{gs}		-	10	-	nC
Gate-Drain Charge	Q_{gd}		-	11	-	nC
Source-Drain Characteristics						
Diode Forward Voltage	V_{sd}	$V_{GS}=0V, I_S=10A$	-	0.8	1.2	V
Reverse Recovery Time	t_{rr}	$V_R=40V, I_F=20A,$ $di/dt=100A/\mu s$	-	112	-	ns
Reverse Recovery Charge	Q_{rr}		-	190	-	nC



Characteristics Curves

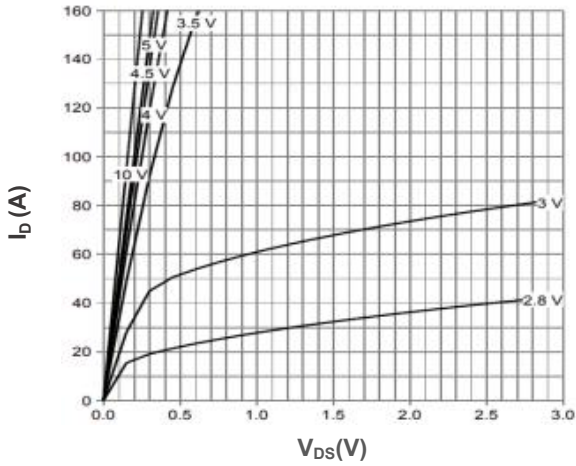

Output Characteristics

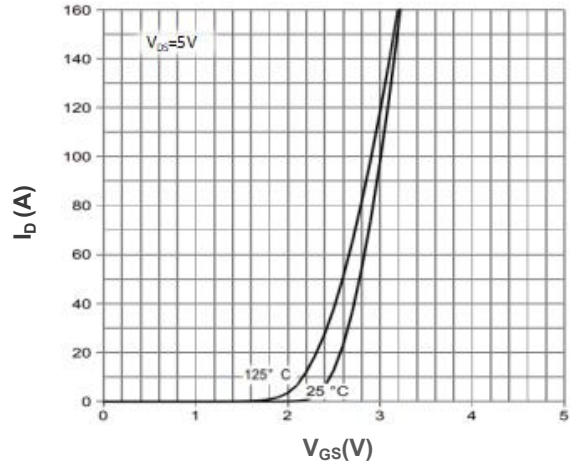

Transfer Characteristics

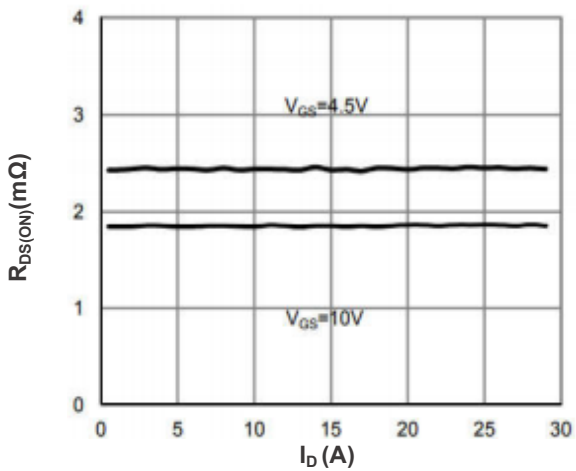

On Resistance Vs Drain Current

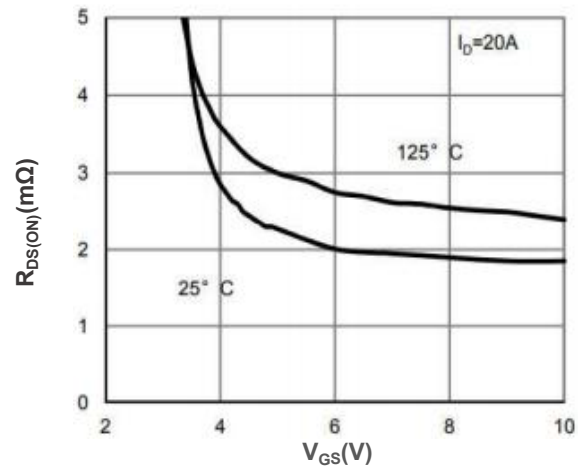

On Resistance Vs Gate Source Voltage

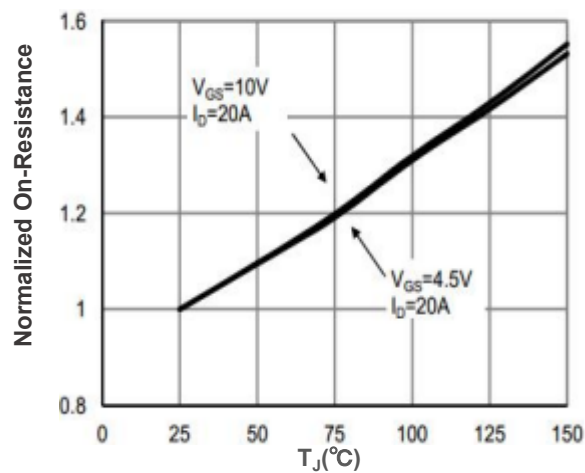

Rdson-JunctionTemperature

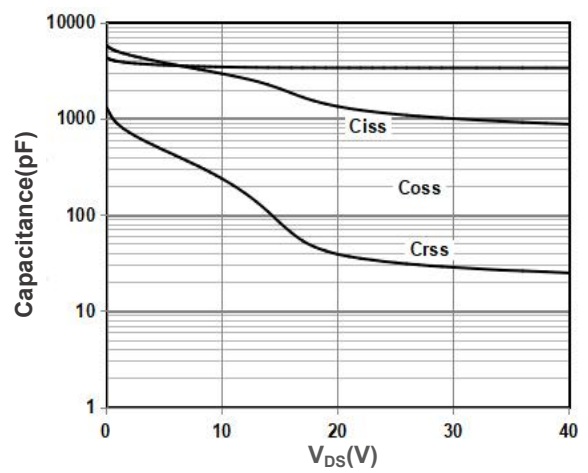

Capacitance

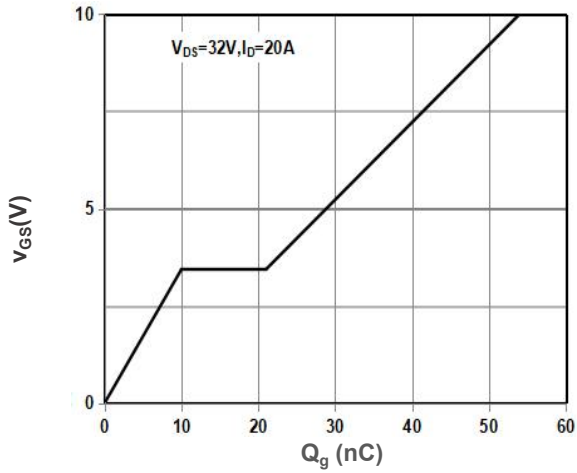

Gate Charge Waveform

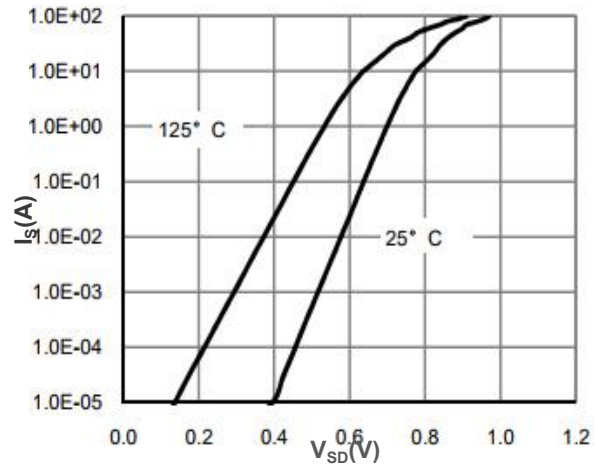

Source-Drain Diode Forward Voltage

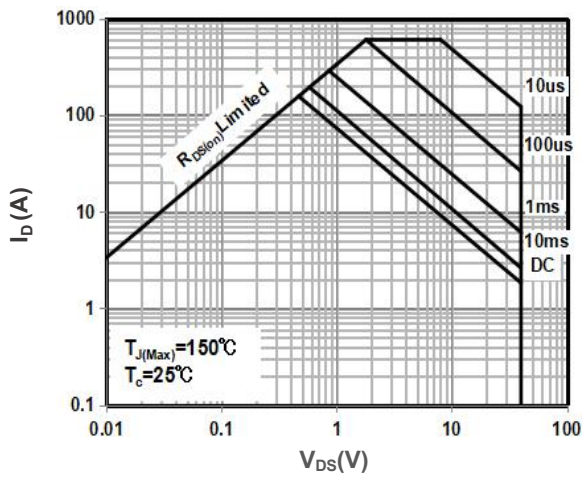

Maximum Safe Operating Area

Note : The above characteristics curves are presented for reference only and not guaranteed by production test, unless otherwise noted.



Test Circuit & Waveform

Gate Charge Test Circuit & Waveform

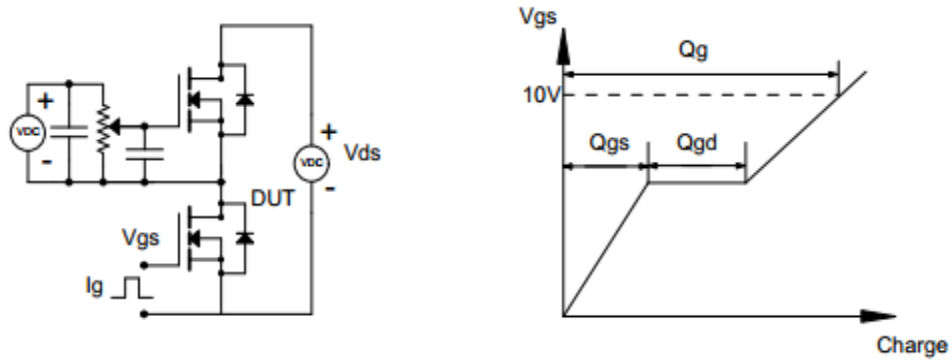

Resistive Switching Test Circuit & Waveform

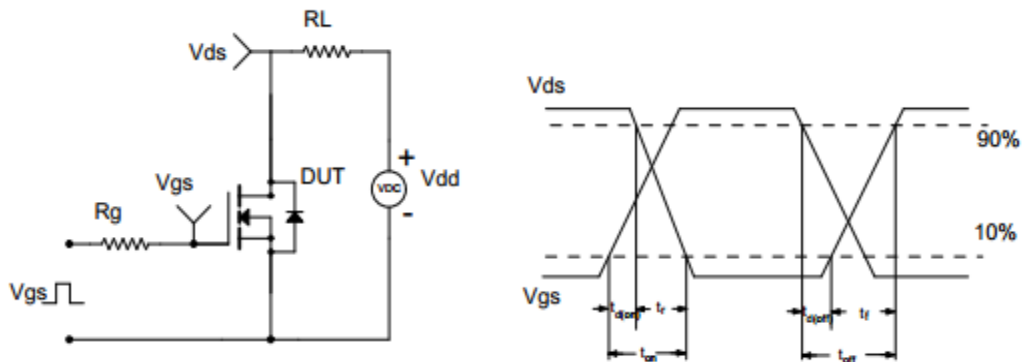

Unclamped Inductive Switching (UIS) Test Circuit & Waveform

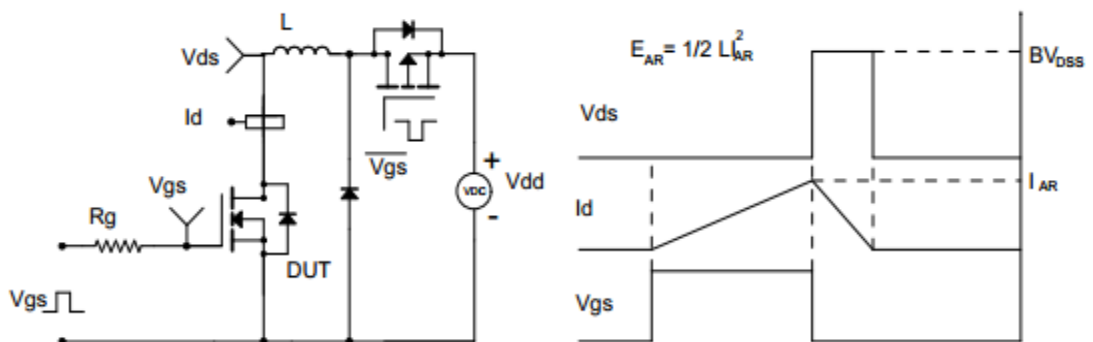



» TOLT Package Dimensions

Unit: mm

Symbol	Min	Nom	Max	Symbol	Min	Nom	Max
A	2.25	2.30	2.35	D3	2.5		3.0
A1	1		1.08	e	1.18	1.20	1.22
A2	0.01		0.16	E	9.7		10.1
b	0.68	0.70	0.74	E1		9.1	
c	0.45	0.50	0.55	E2		8.2	
D	14.80		15.20	H	4.84		5.25
D1	10.00		10.30	L	2.40		2.50
D2		5.7					

