



Applications

- Switch Mode Power Supplies
- High Voltage DC/DC Converters
- Battery Chargers
- Motor Drives
- Pulsed Power applications

Features

- High Blocking Voltage with Low On-Resistance
- High Speed Switching with Low Capacitances
- Wide Bandgap SiC MOSFET Technology
- Low Reverse Recovery (Qrr)

Benefits

- Higher System Efficiency
- Reduced Cooling Requirements
- Increased Power Density
- Increased System Switching Frequency

Product Summary

V_{DS}	650	V
I_D	10	A
$R_{DS(ON)}, Typ@15V$	260	mΩ
Q_g	25	nC



TO-220F

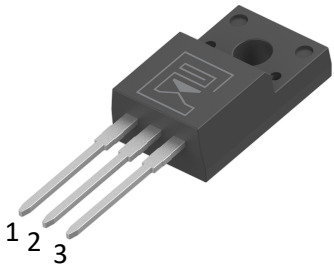

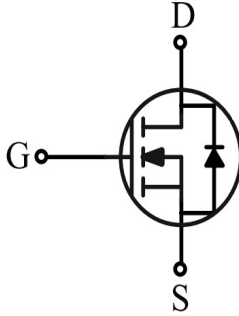

Gate: 1

Drain: 2

Source: 3

Package Marking and Ordering Information

Ordering code	Marking	Package	Packaging	Min. package quantity
MF3C260R065	MF3C260R065	TO-220F	Tube	1000



➤➤ Absolute Maximum Ratings (Tc=25°C unless otherwise noted)

Parameter	Symbol	Ratings	Unit
Drain-Source Voltage	V_{DS}	650	V
Gate-Source Voltage	V_{GS}	- 10/+22	V
Recommended operational values	V_{GSop}	0/+18	V
Continuous Drain Current Tc=25°C VGS=15V (Note 1)	I_D	10	A
Continuous Drain Current Tc=100°C VGS=15V (Note 1)		7	A
Drain Current-Pulsed (Note 1)	I_{DM}	20	A
Total Dissipation	P_D	25	W
Junction Temperature	T_j	175	°C
Storage Temperature	T_{stg}	- 55~175	°C
Single Pulse Avalanche Energy (Note 2)	E_{AS}	90	mJ

Note: Using continuously under heavy loads (e.g. the application of high temperature/current/voltage and the significant change in temperature, etc.) may cause this product to decrease in the reliability even if the operating conditions (i.e. operating temperature/current/voltage, etc.) are within the absolute maximum ratings.

➤➤ Thermal Characteristics

Parameter	Symbol	Max	Unit
Maximum Junction-to-Case	$R_{\theta JC}$	6	°C/W
Maximum Junction-to-Ambient	$R_{\theta JA}$	80	°C/W

Note 1: Ensure that the channel temperature does not exceed 175°C.

Note 2: VDD=100V, Tch= 25°C(initial), L=0.5mH

Note: This transistor is sensitive to electrostatic discharge and should be handled with care.



» Electrical Characteristics (Tc=25°C unless otherwise noted)

Parameter	Symbol	Test Condition	Min	Typ	Max	Unit
Static Parameters						
Drain-Source Breakdown Voltage	BV_{DSS}	$V_{GS}=0V, I_D=500\mu A$	650	-	-	V
Drain-Source Leakage Current	I_{DSS}	$V_{DS}=650V, V_{GS}=0V$	-	-	10	μA
Gate-Body Leakage Current	I_{GSS}	$V_{GS}=18V, V_{DS}=0V$	-	-	250	nA
Gate Threshold Voltage	$V_{GS(TH)}$	$V_{GS}=V_{DS}, I_{DS}=1.5mA$	2.5	3.4	4.0	V
Drain-Source On Resistance	$R_{DS(ON)}$	$V_{GS}=15V, I_D=6.5A$	-	260	320	m Ω
		$T_j=175^\circ C$	-	210	-	
		$V_{GS}=18V, I_D=6.5A$	-	180	240	
		$T_j=175^\circ C$	-	200	-	
Dynamic Characteristics						
Input Capacitance	C_{iss}	$V_{DS}=25V, V_{GS}=0V, f=1.0MHz$	-	399	-	pF
Output Capacitance	C_{oss}		-	110	-	pF
Reverse Transfer Capacitance	C_{rss}		-	6	-	pF
Gate Resistance	R_g	$V_{DS}=0V, V_{GS}=0V, f=1.0MHz$	-	3.2	-	Ω
Switching Parameters						
Turn-On Delay Time	$t_{d(on)}$	$V_{DD}=500V, V_{GS}=0/15V, I_D=6.5A, R_{G(ext)}=2\Omega$	-	14	-	ns
Turn-On Rise Time	t_r		-	42	-	ns
Turn-Off Delay Time	$t_{d(off)}$		-	20	-	ns
Turn-Off Fall Time	t_f		-	43	-	ns
Turn-On Switching Energy	E_{ON}		-	45	-	μJ
Turn-Off Switching Energy	E_{OFF}		-	6.1	-	
Total Gate Charge	Q_g		$V_{DD}=500V, V_{GS}=0/15V, I_D=6.5A$	-	25	-
Gate-Source Charge	Q_{gs}	-		11	-	nC
Gate-Drain Charge	Q_{gd}	-		9	-	nC
Source-Drain Characteristics						
Diode Forward Voltage	V_{sd}	$V_{GS}=0V, I_{SD}=3.5A,$	-	3.3	-	V
Continuous Diode Forward Current	I_S	$T_C=25^\circ C$	-	10	-	A
Reverse Recovery Time	t_{rr}	$V_R=400V, I_F=10A, di/dt=1250A/\mu s$	-	9.8	-	ns
Reverse Recovery Charge	Q_{rr}		-	26.5	-	nC
Peak Reverse Recovery Current	I_{rrm}		-	5.4	-	A



Characteristics Curves

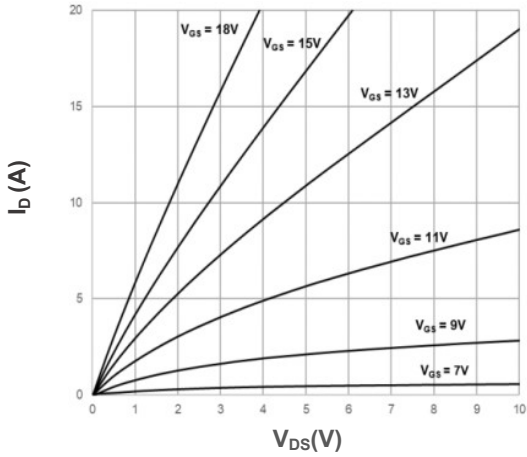

Output Characteristics $T_J = 25^\circ\text{C}$

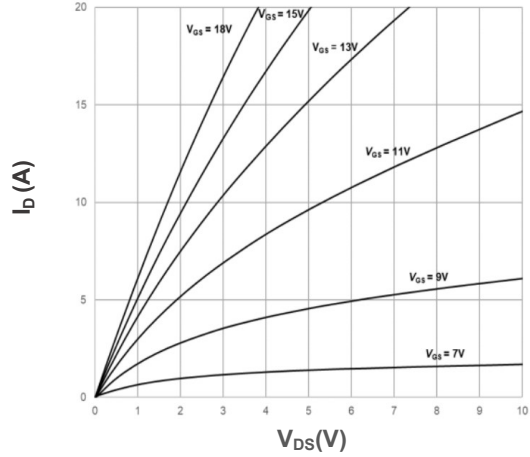

Output Characteristics $T_J = 175^\circ\text{C}$

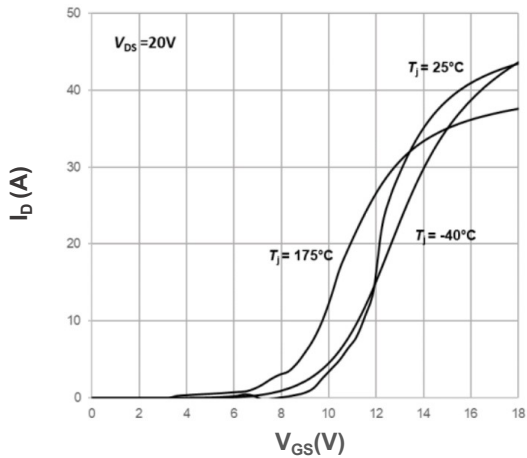

Transfer Characteristics

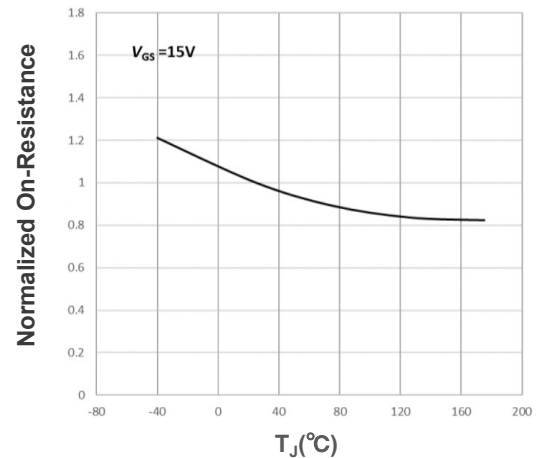

Normalized On-Resistance vs. Temperature

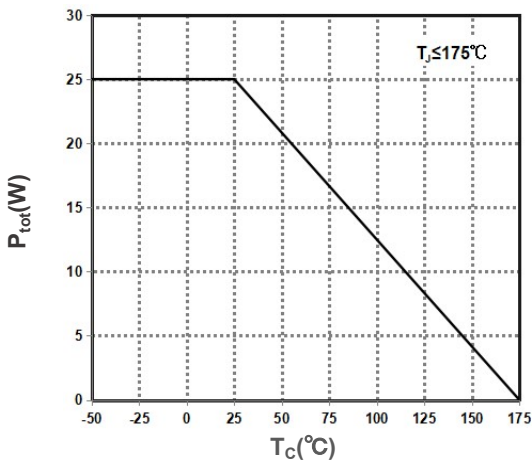

Power Dissipation Derating

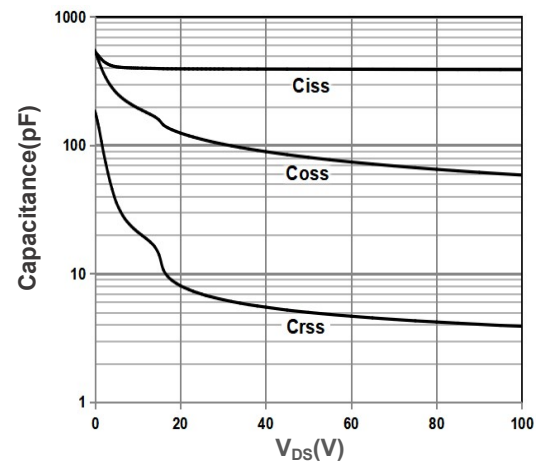

Capacitance

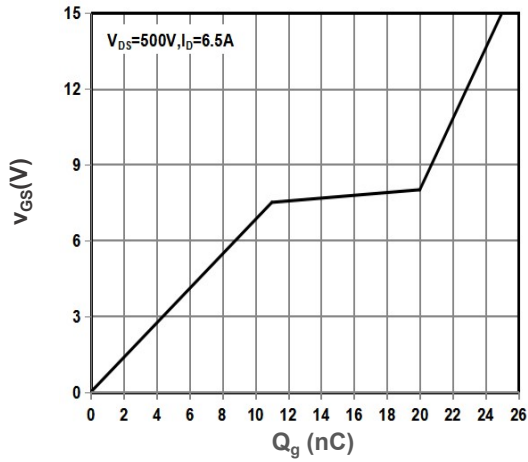

Gate Charge Waveform

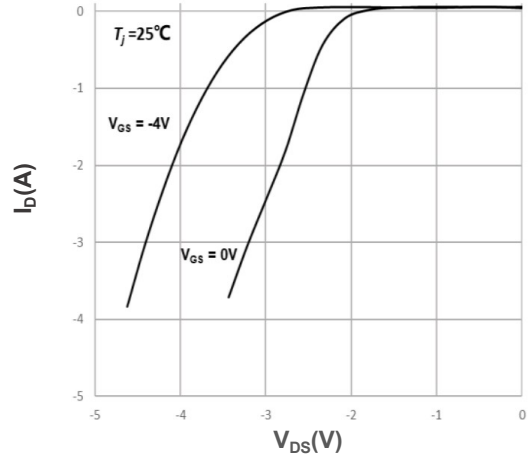

Source-Drain Diode Characteristics, $T_j=25^\circ C$

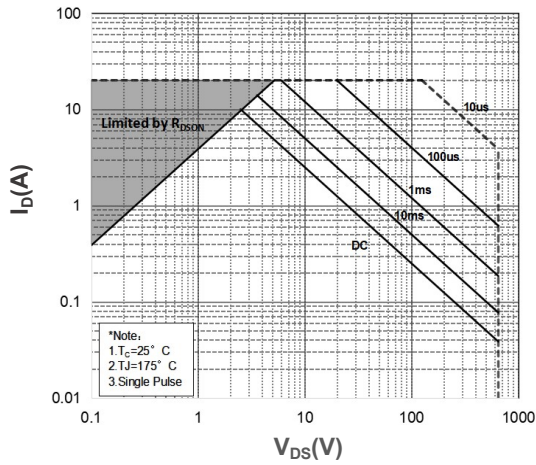

Safe Operating Area

Note: The above characteristics curves are presented for reference only and not guaranteed by production test, unless otherwise noted.



» Test Circuit & Waveform

Gate Charge Test Circuit & Waveform

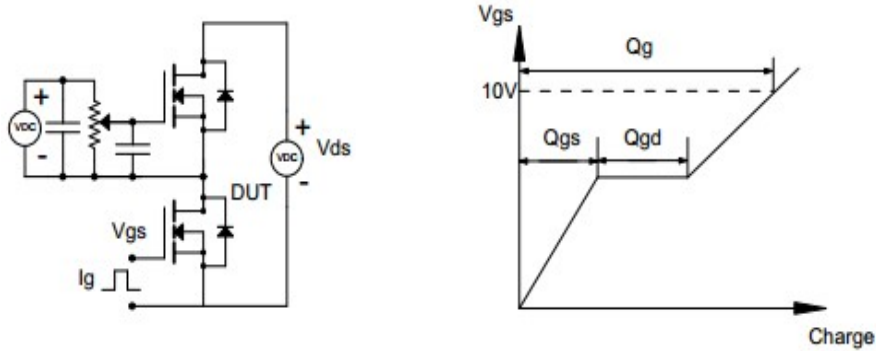

Resistive Switching Test Circuit & Waveform

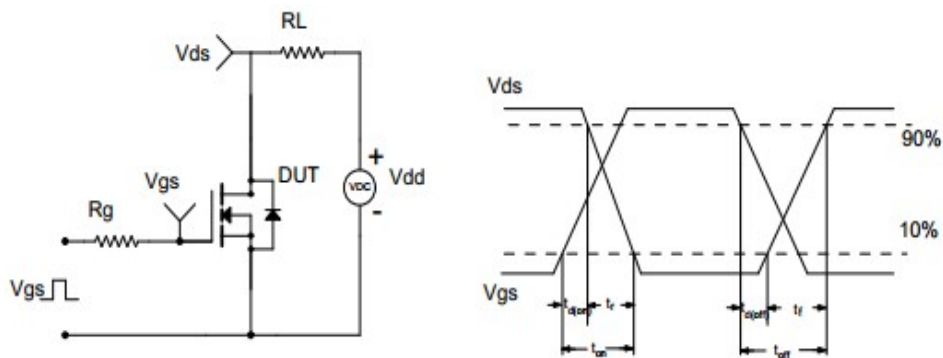

Unclamped Inductive Switching (UIS) Test Circuit & Waveform

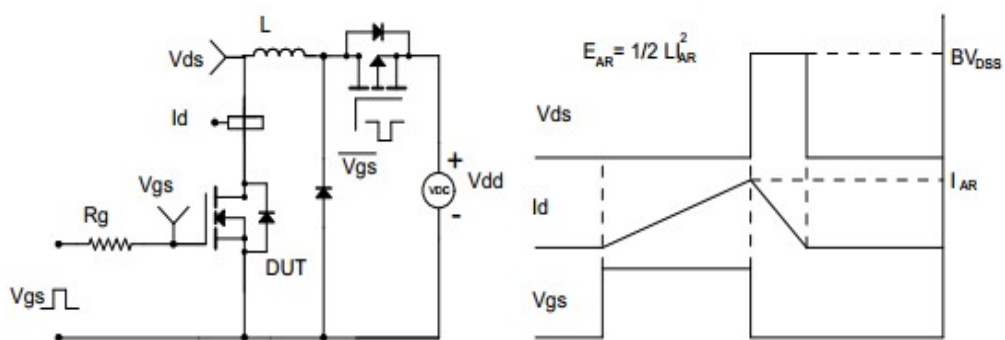



TO-220F Package Dimensions

Unit: mm

Symbol	Min	Nom	Max	Symbol	Min	Nom	Max
A	4.5		4.9	e	2.44	2.54	2.64
A1	2.3		2.9	L	12.5		14.3
b	0.65		0.9	L1	9.45		10.05
b1	1.2		1.4	L2	15		16
c	0.35		0.65	L3	3.2		4.4
D	14.5		16.5	L4	0.7		0.9
D1	6.1		6.9	ΦP	3		3.3
E	9.6		10.3	Q	2.5		2.9
E1	6.5	7	7.5				

